

1 POLICE WALL LAYOUT
45-01 SCALE: 1"=1'-0"

Yale Repertory Theatre
Yale School Of Drama
222 York Street
New Haven, CT 06510

ACCIDENTAL DEATH OF AN ANARCHIST

POLICE WALL LAYOUT

Director:
C. BAYES

Designer:
K. NOLL

T.D.:
J. YOUNG

Scale:
As Noted

Date:
12/6/15

Inventory Code:
450

Plate number:
450-001

Drawn By:
K. MATSUMOTO

File: G:\Productions\2013-2014 Season\YRT3 - Accidental Death of an Anarchist\Scenery\Technical\Drafting\450 Police Station Walls\450 Police Station Walls.dwg



Yale Repertory Theatre
Yale School of Drama
222 York Street
New Haven, CT 06510

ACCIDENTAL DEATH OF AN ANARCHIST

FALLING WALLS

Director:
C. BAYES

Designer:
K. NOLL

T.D.:
J. YOUNG

Scale:
As Noted

Date:
12/6/15

Inventory Code:
450

Plate number:

450-002

Drawn By:
K. MATSUMOTO

File: G:\Productions\2013-2014 Season\YRT3 - Accidental Death of an Anarchist\Technical\Drafting\450 Poice Station Walls\450 Poice Station Walls.dwg

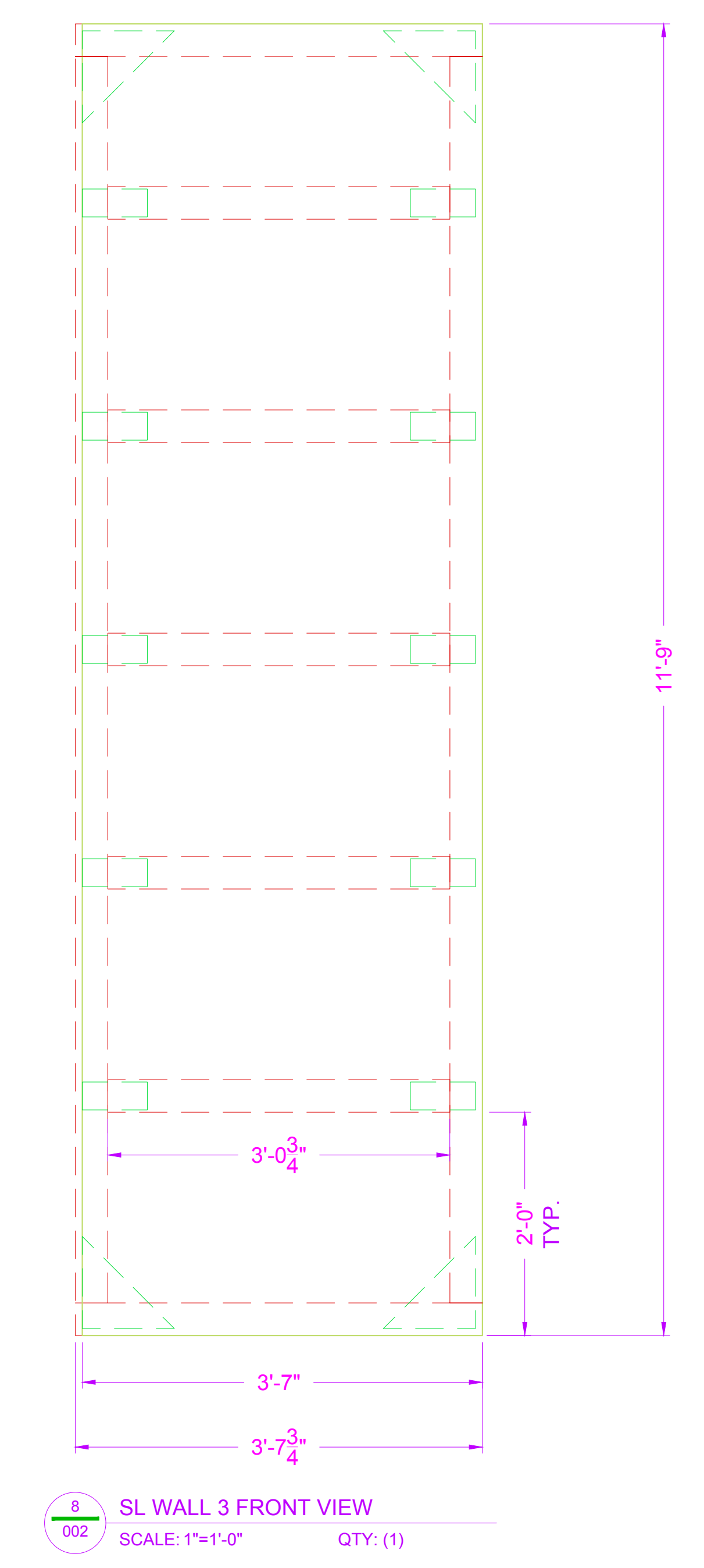
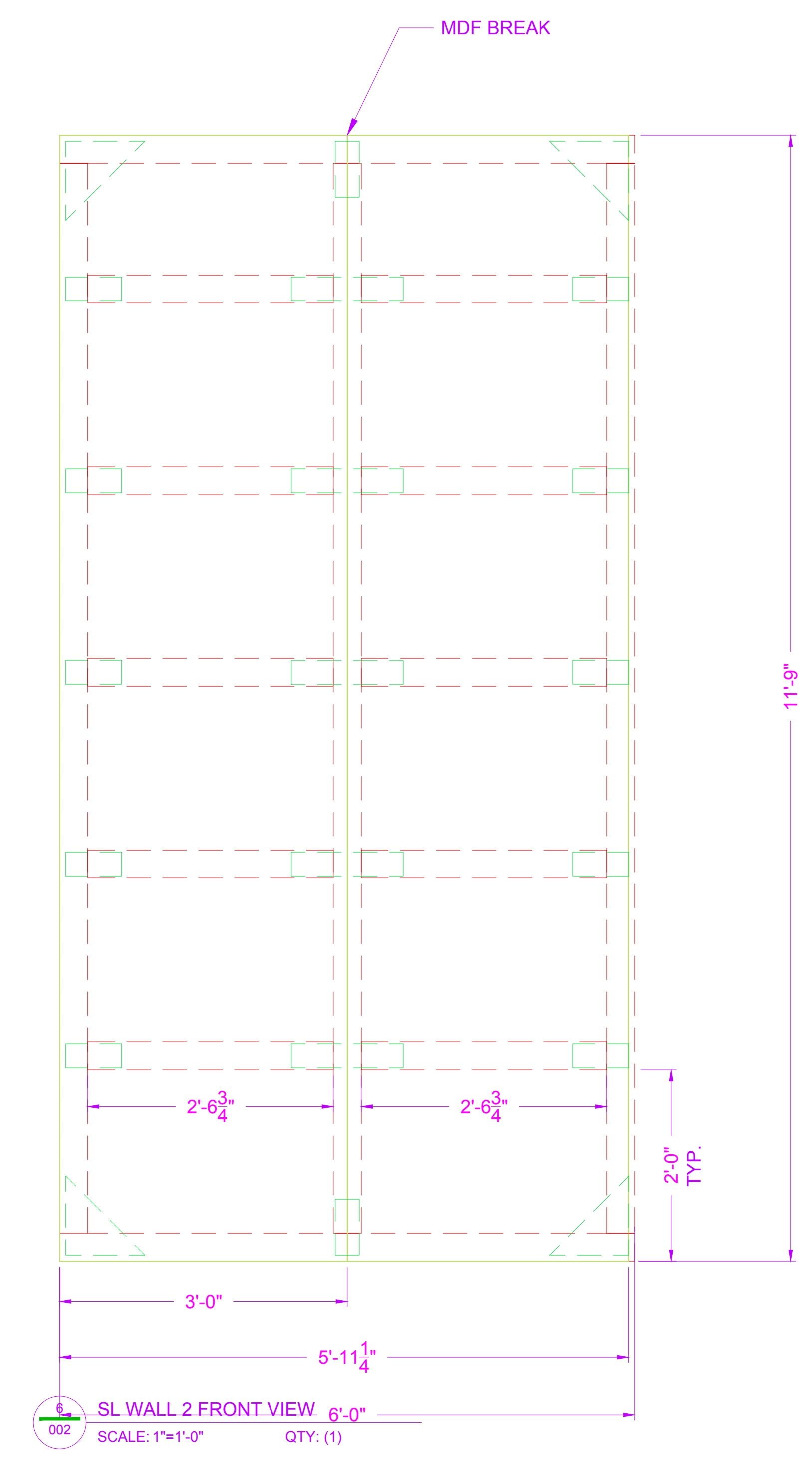
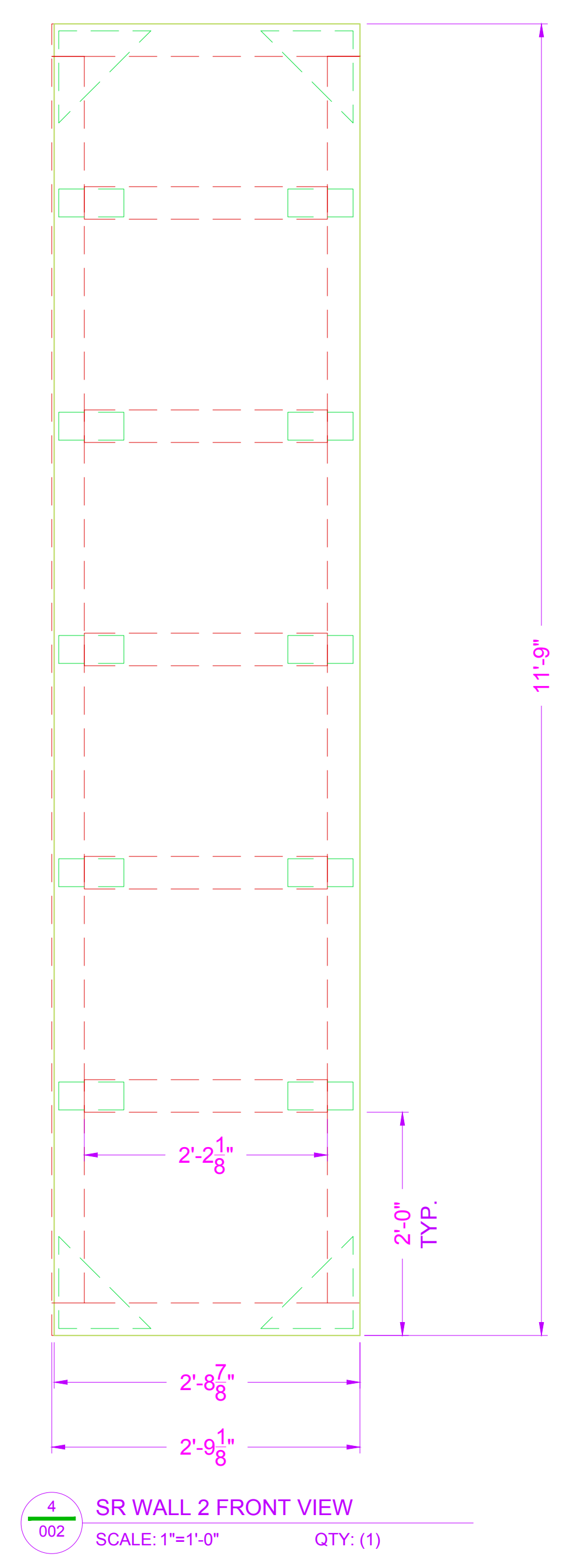
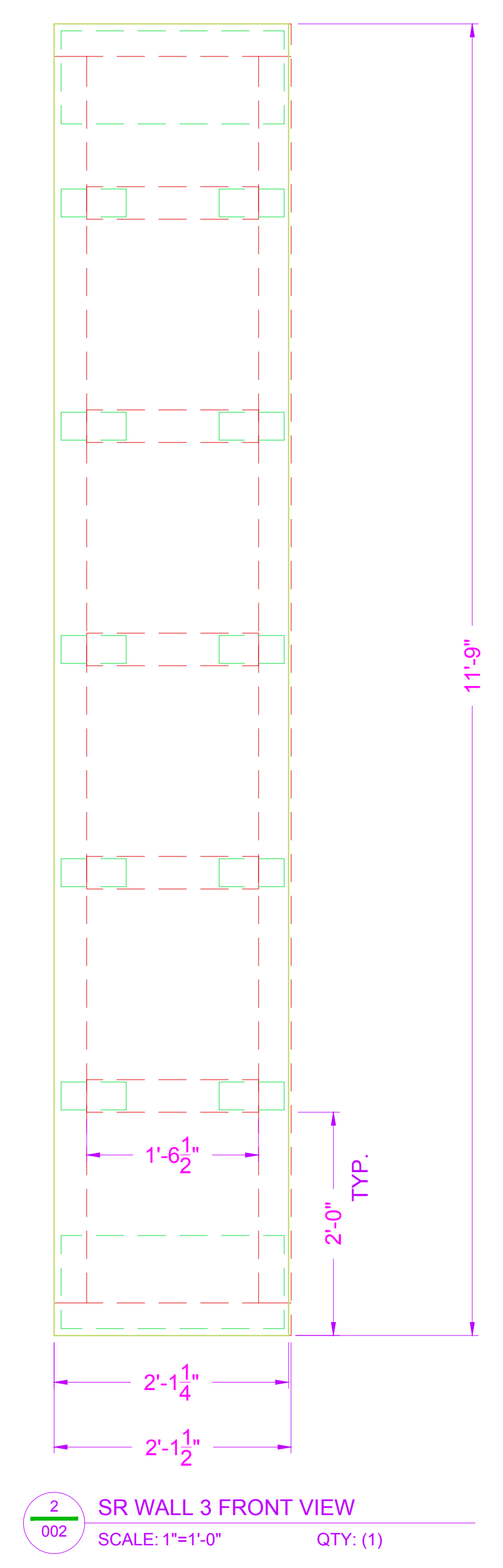
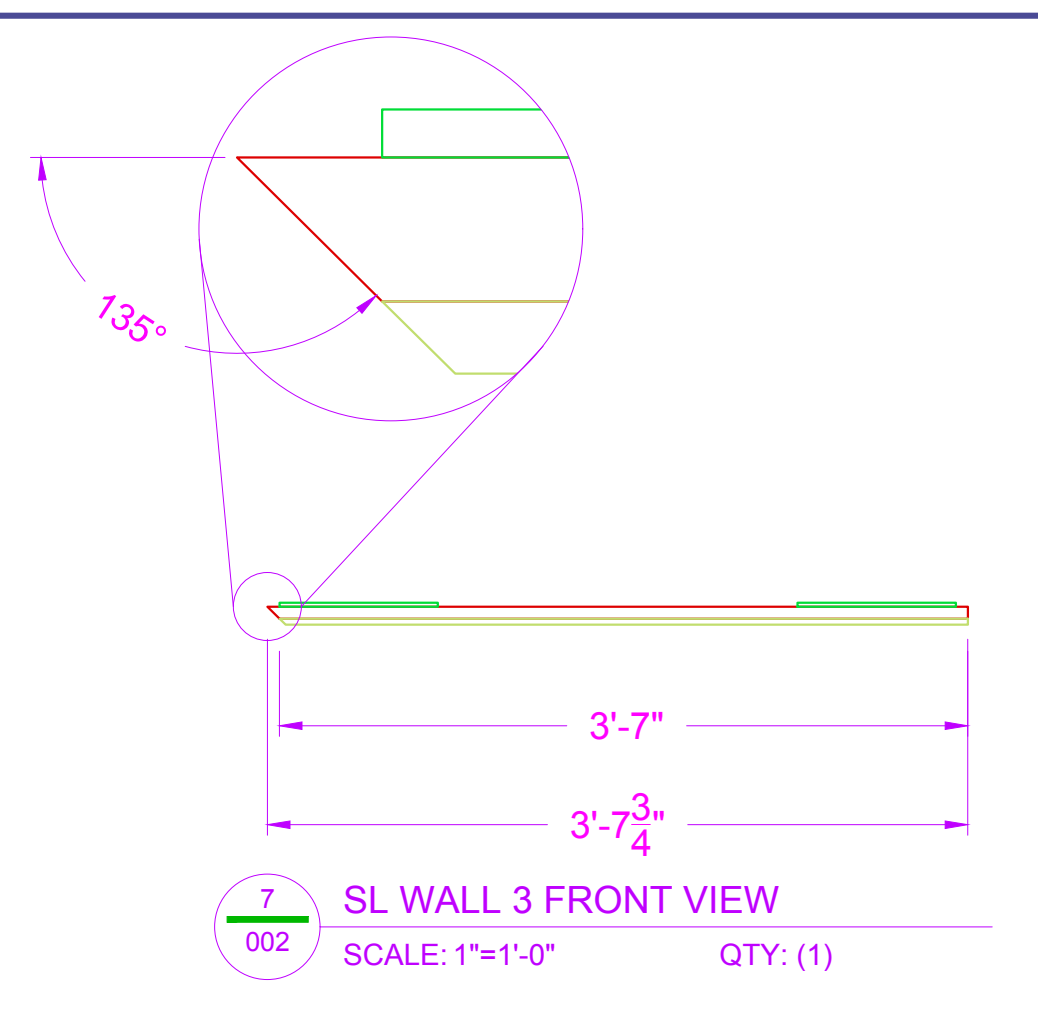
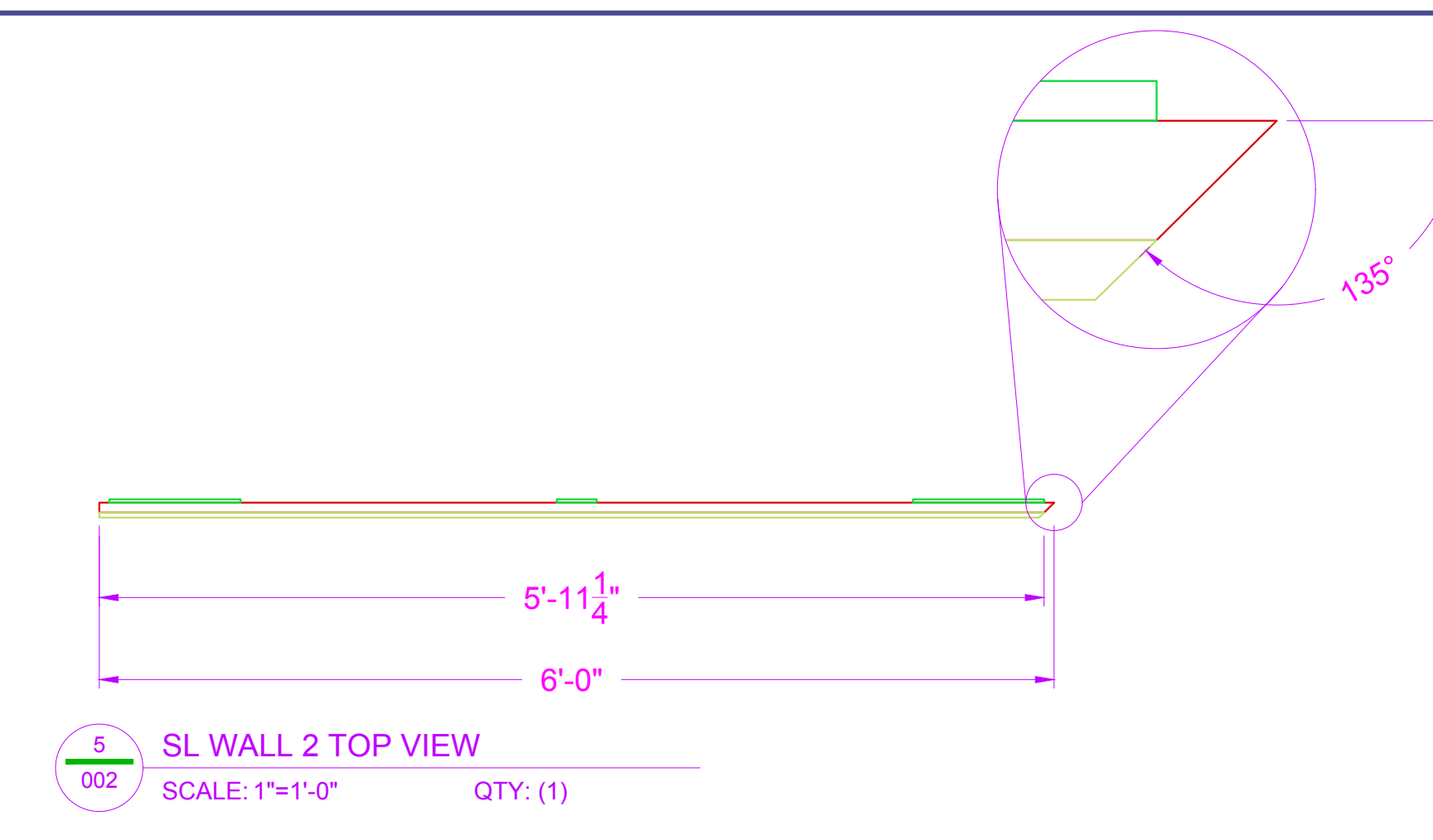
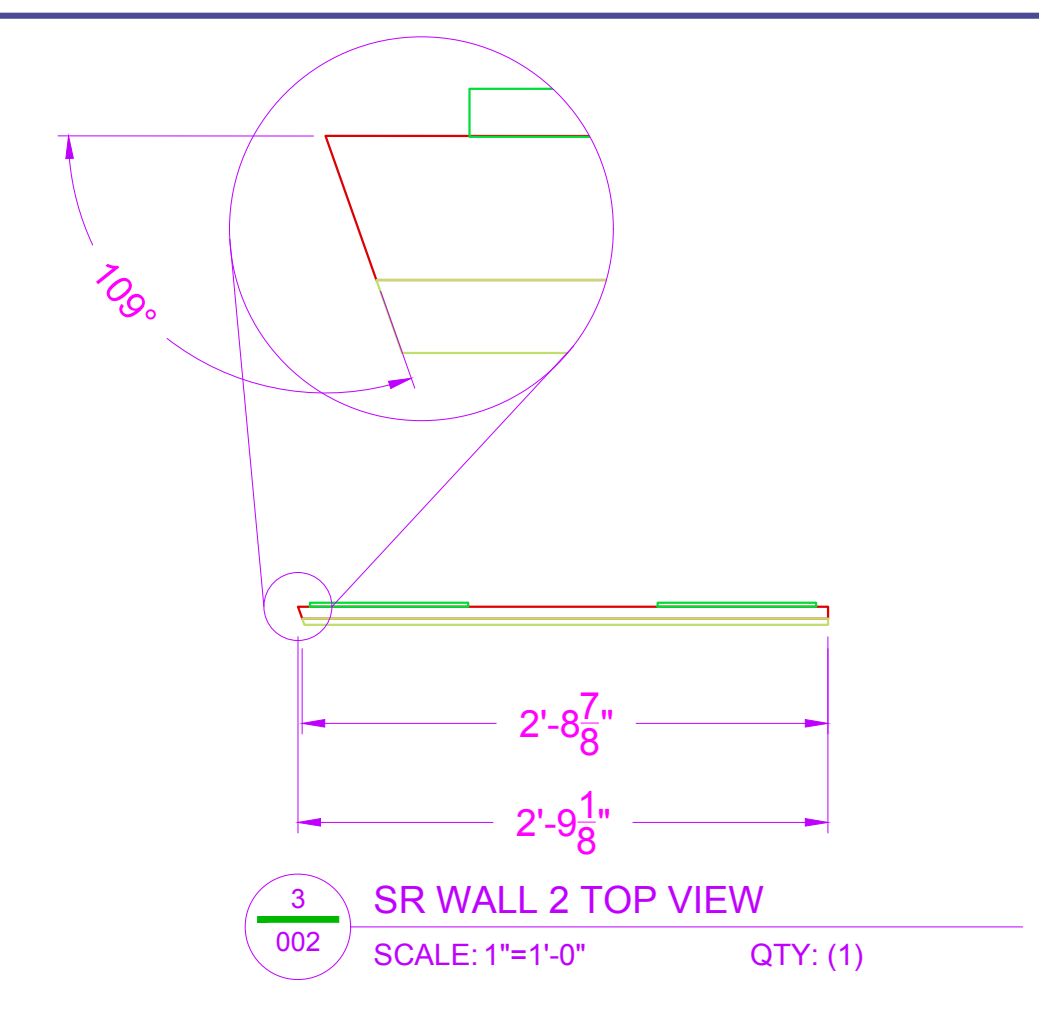
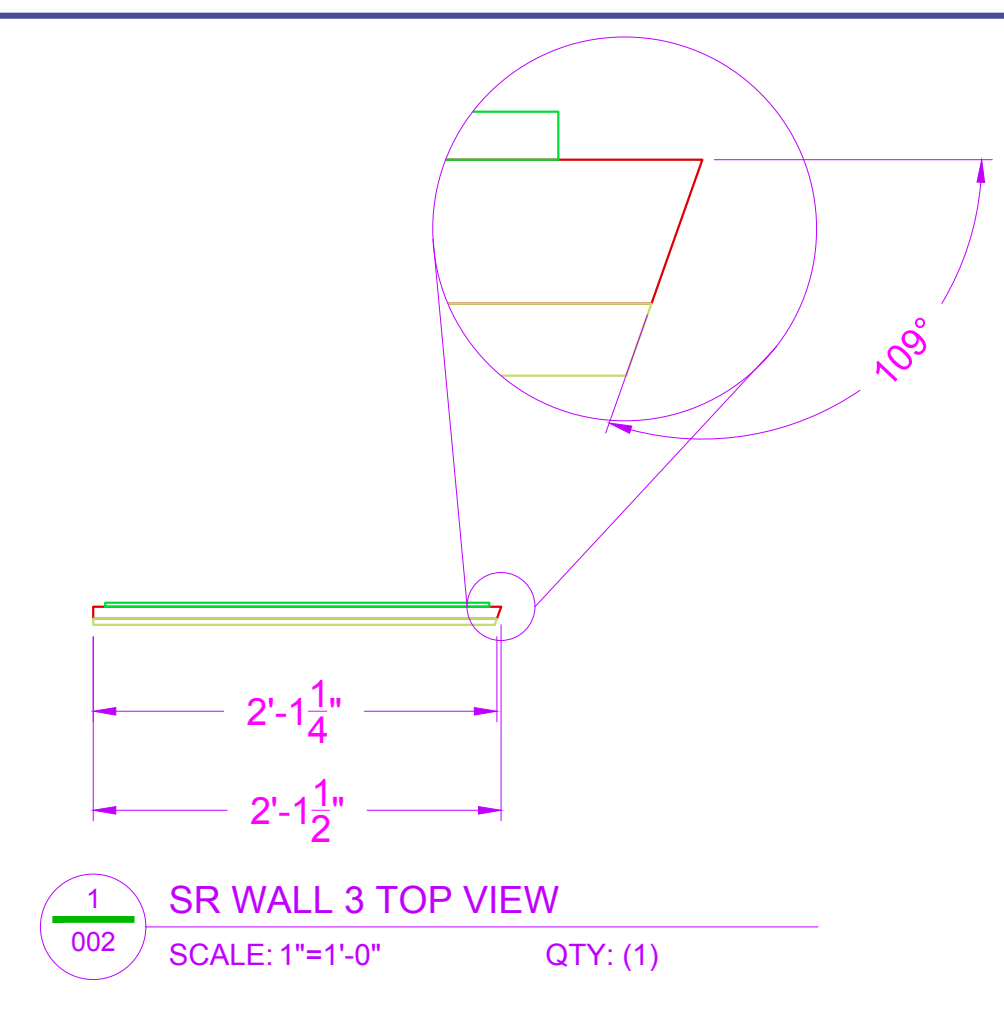

NOTE:
 BROADWAY FLAT
 1x4 PINE, 3/8"x4"x12' MDF FACING
 1/4" PLY KEYSTONES AND CORNERBLOCKS
 PUTTY AND SAND SEAMS AND HOLES

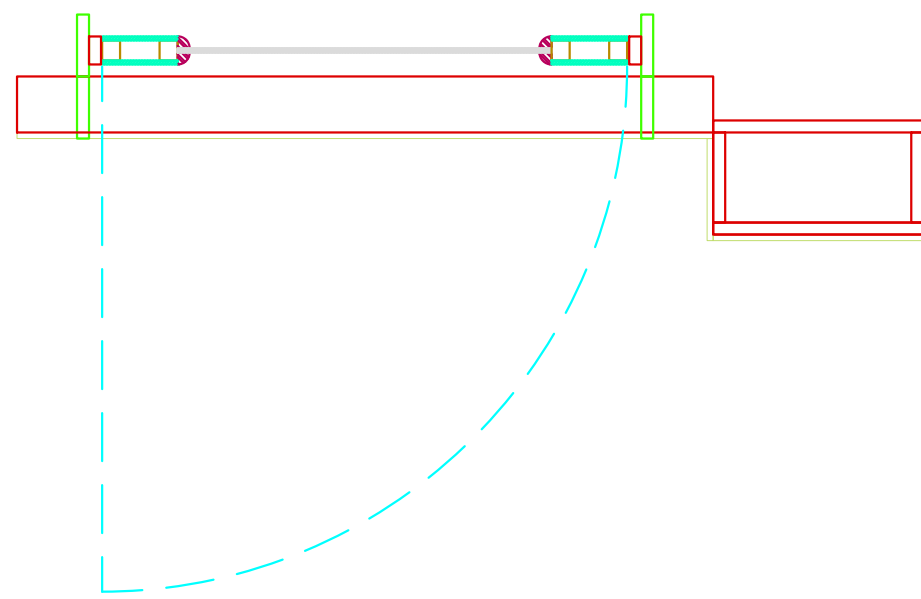

1 SR DOOR WALL - TOP ASSEMBLED VIEW
SCALE: 1"=1'-0" QTY: (1)

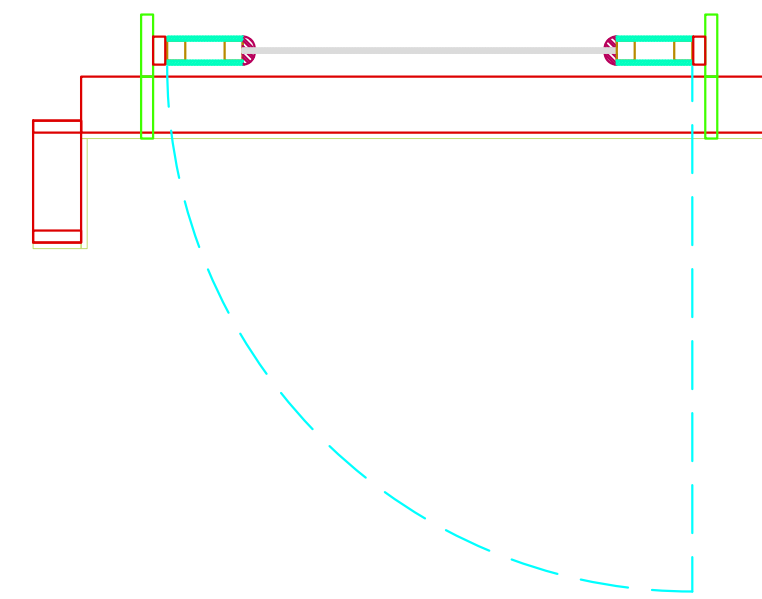

4 SL DOOR WALL - TOP ASSEMBLED VIEW
SCALE: 1"=1'-0" QTY: (1)

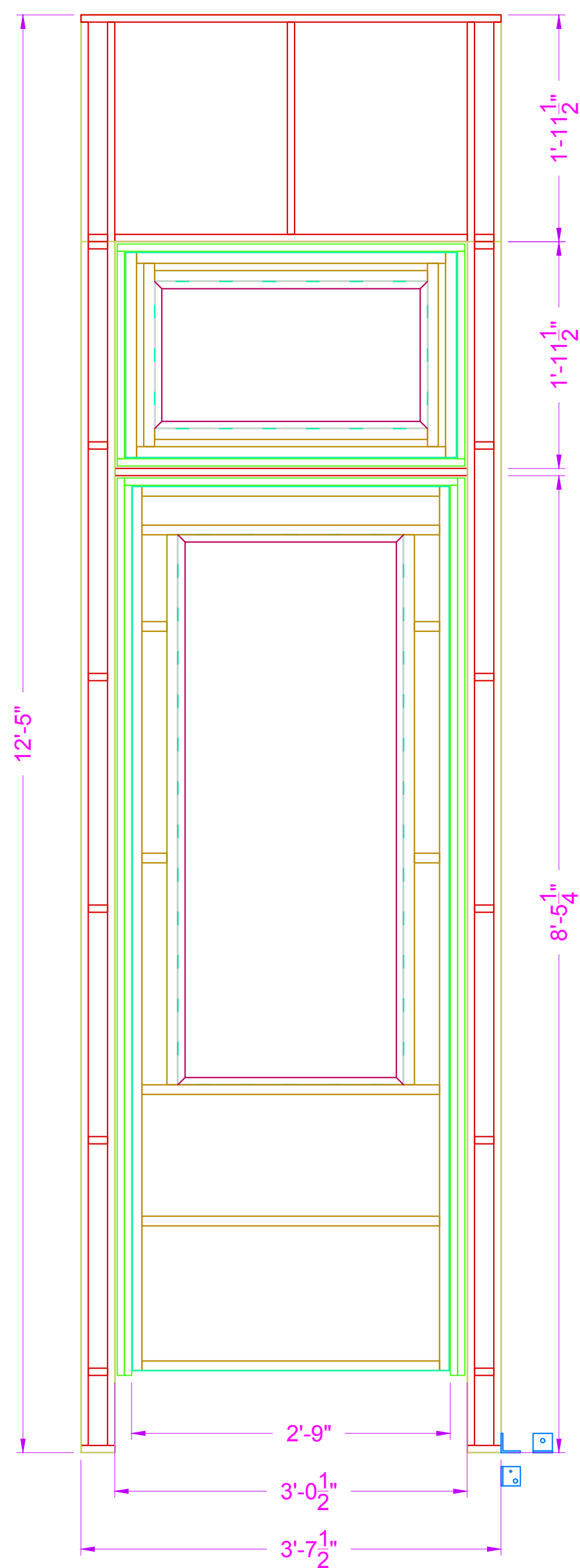

2 SR DOOR WALL - ASSEMBLED FRAMING FRONT VIEW
SCALE: 1"=1'-0" QTY: (1)

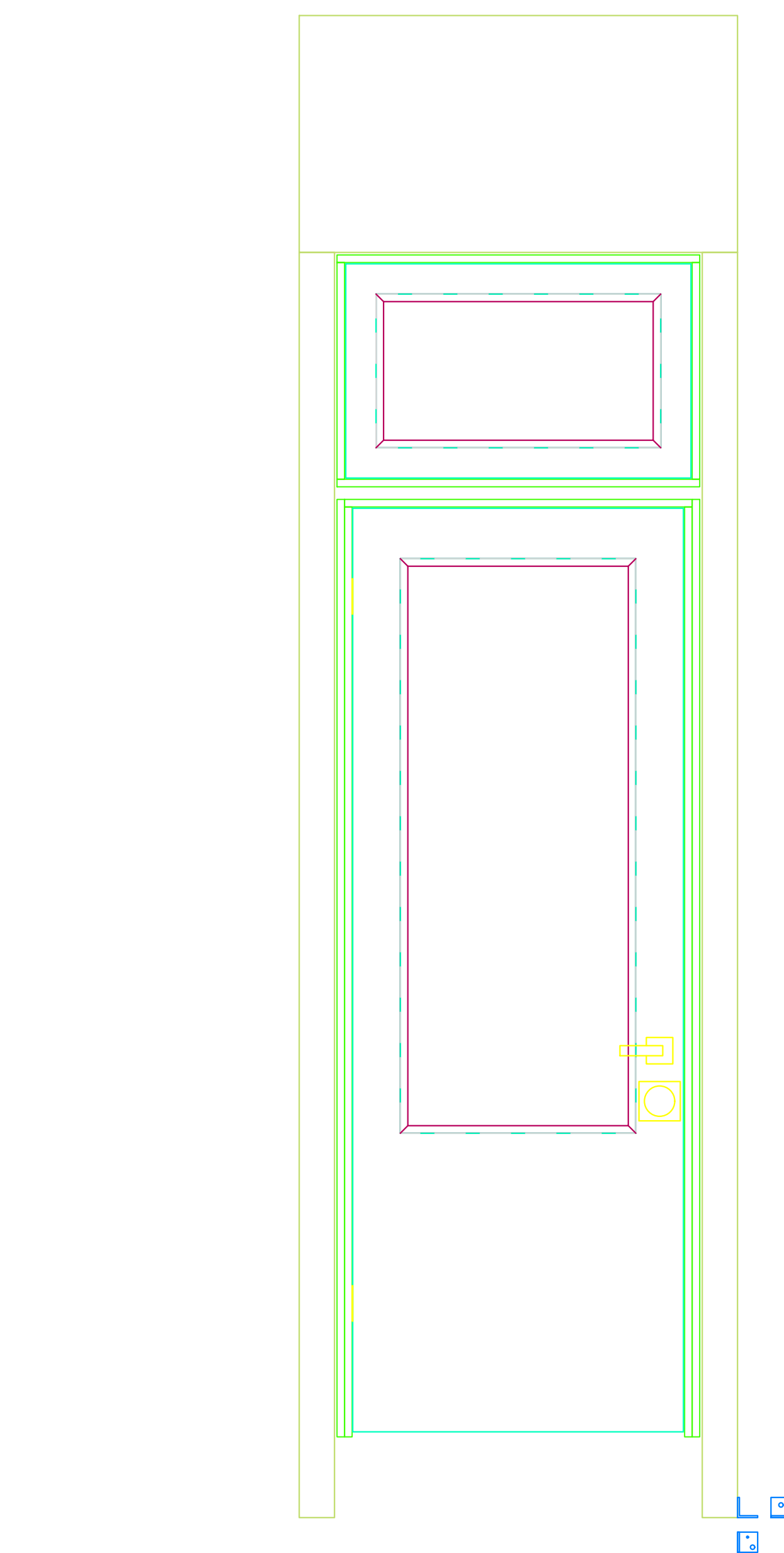

3 SR DOOR WALL - ASSEMBLED FRONT VIEW
SCALE: 1"=1'-0" QTY: (1)

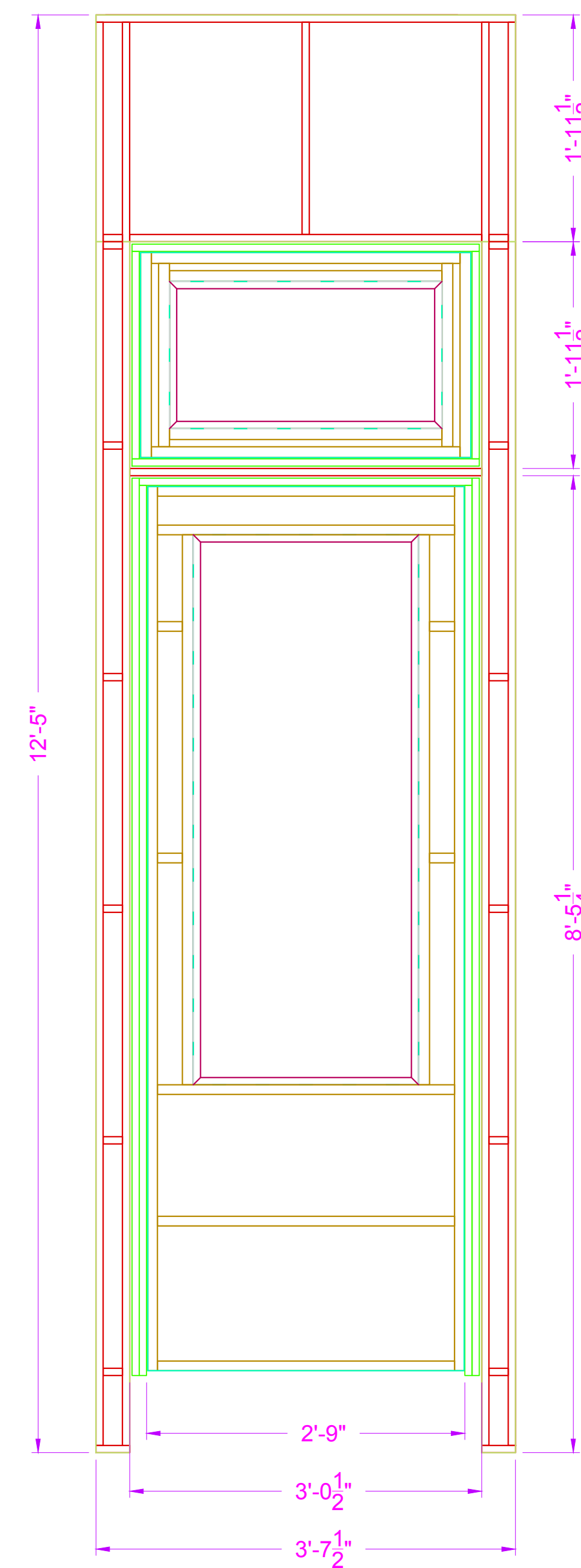

5 SL DOOR WALL - ASSEMBLED FRAMING FRONT VIEW
SCALE: 1"=1'-0" QTY: (1)

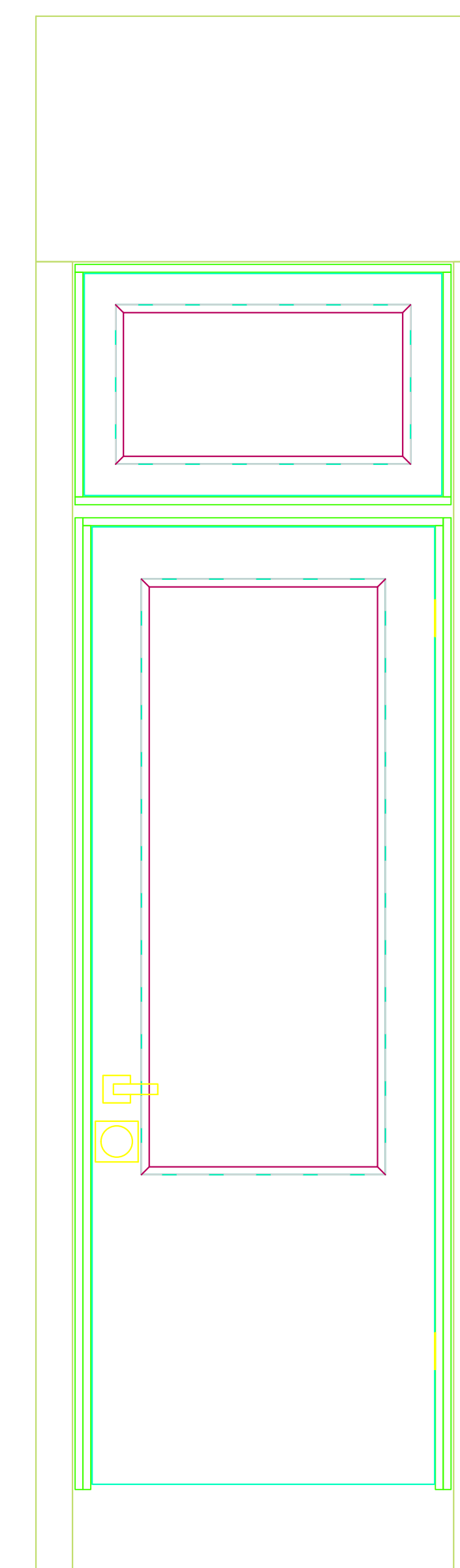

6 SL DOOR WALL - ASSEMBLED FRONT VIEW
SCALE: 1"=1'-0" QTY: (1)



Yale Repertory Theatre
Yale School Of Drama
222 York Street
New Haven, CT 06510

ACCIDENTAL DEATH OF AN ANARCHIST

SR DOOR WALL AND SL DOOR WALL - ASSEMBLED

Director:
C. BAYES

Designer:
K. NOLL

T.D.:
J. YOUNG

Scale:
As Noted

Date:
12/6/15

Inventory Code:
450

Plate number:

450-008

Drawn By:
K. MATSUMOTO

Station Walls.dwg
Accidental Death of an Anarchist\Scenery\Technical\Drafting\450 Poice Station Walls\450 Poice

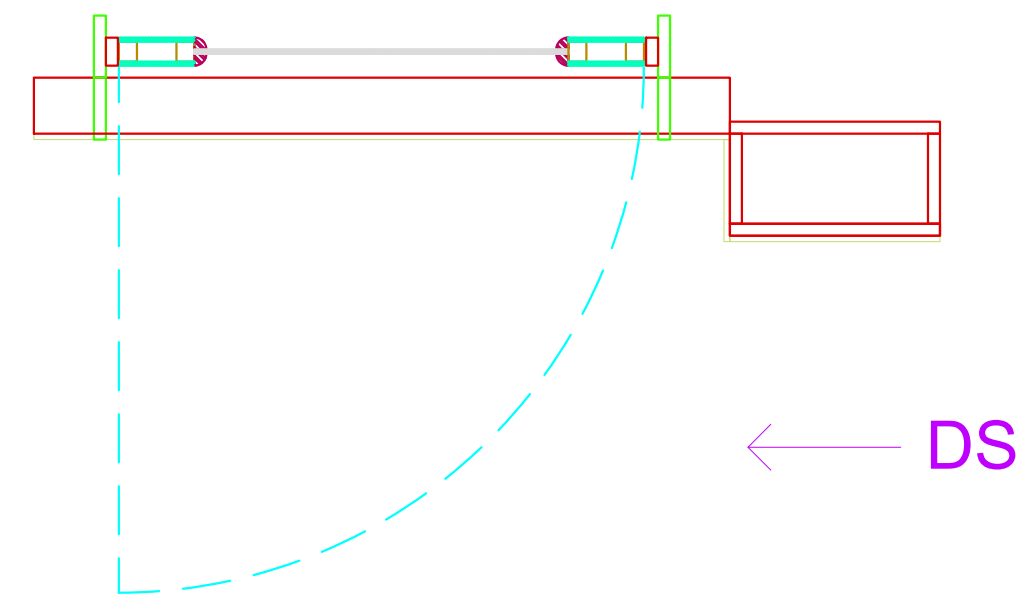

NOTE:
 1x4 PINE FRAMING (HOLLYWOOD FLATS)
 3/8" MDF FACING
 OPEN CENTER WITH ONE TOGGLE TO CATCH THE
 PRE-HUNG DOOR AND TRANSOM
 PUTTY AND SAND ALL STAPLES AND SEAMS

1 SR DOOR WALL - TOP ASSEMBLED VIEW
 SCALE: 1"=1'-0" QTY: (1)

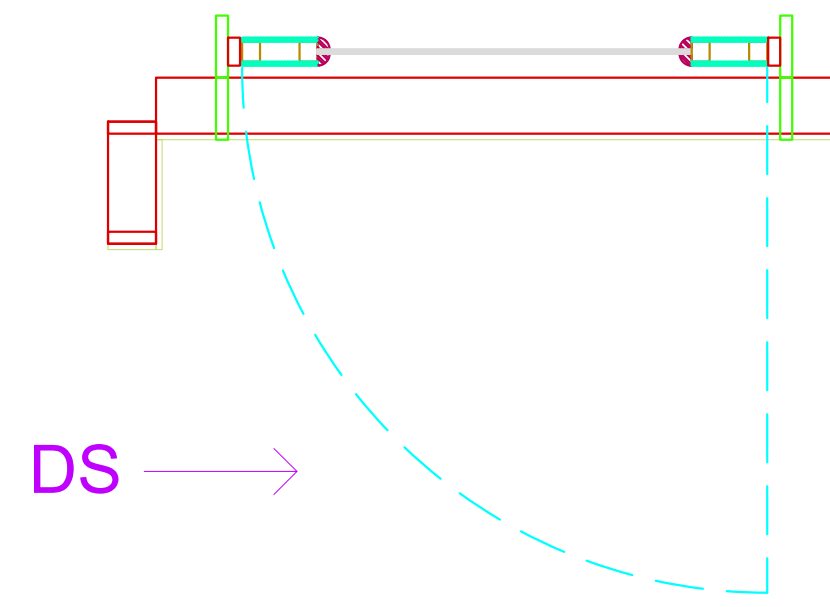

NOTE:
 7 3/4" JAMB CUT OUT OF 3/4" POPLAR
 2"x7'-8 1/4" DOOR STOP CUT OUT OF 1x PINE

2 SL DOOR WALL - TOP ASSEMBLED VIEW
 SCALE: 1"=1'-0" QTY: (1)

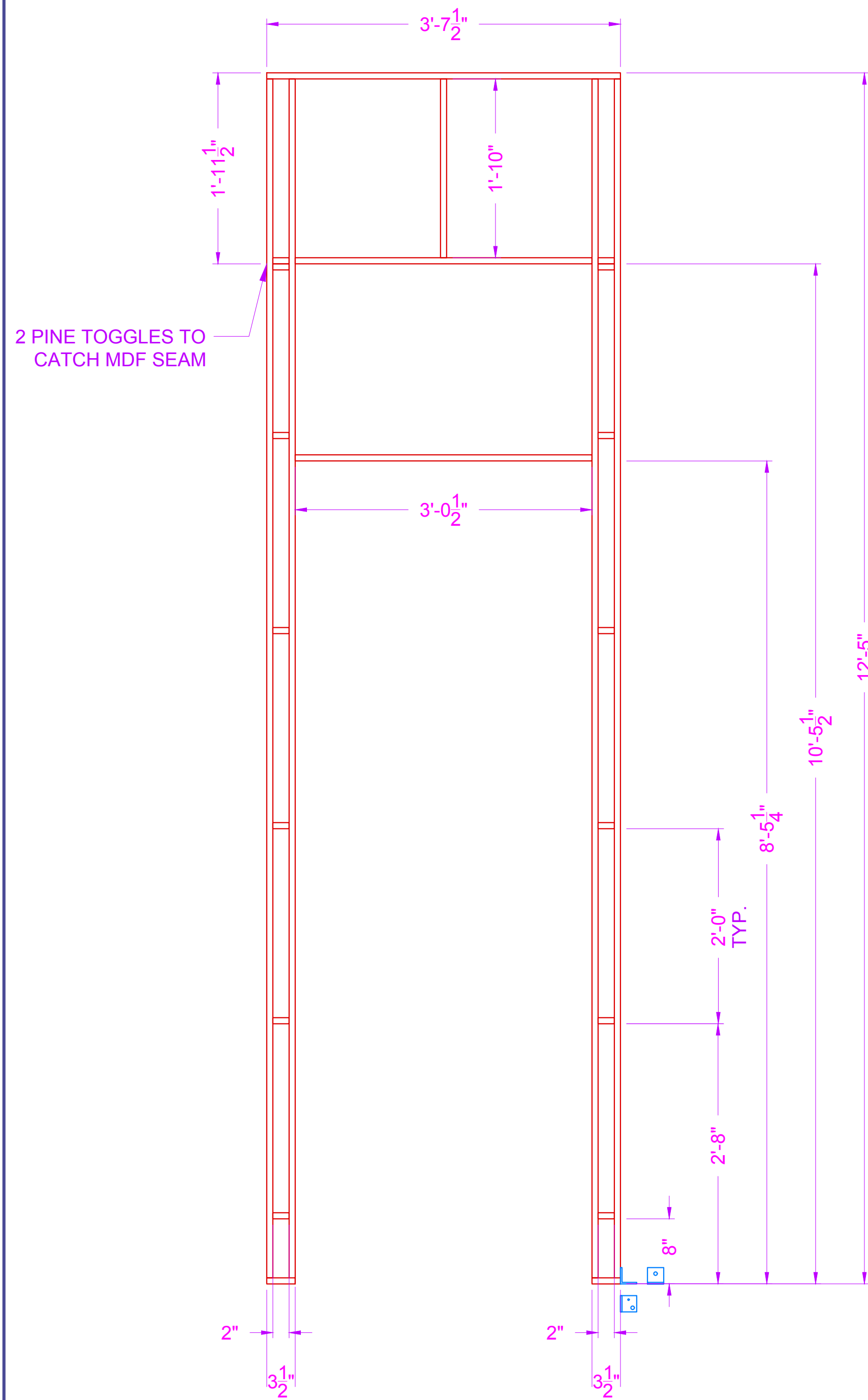

3 SR DOOR WALL - FRONT VIEW - FRAMING
 SCALE: 1"=1'-0" QTY: (2)

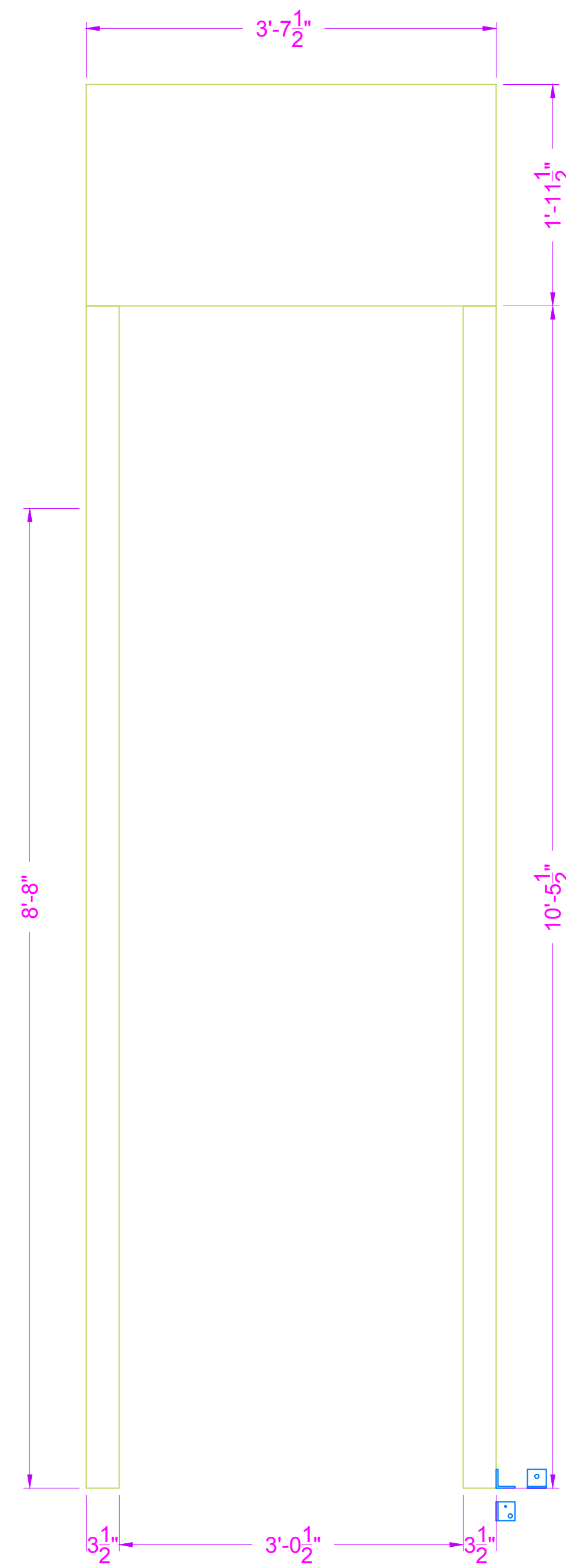

4 SR DOOR WALL - FRONT VIEW - FACING
 SCALE: 1"=1'-0" QTY: (2)

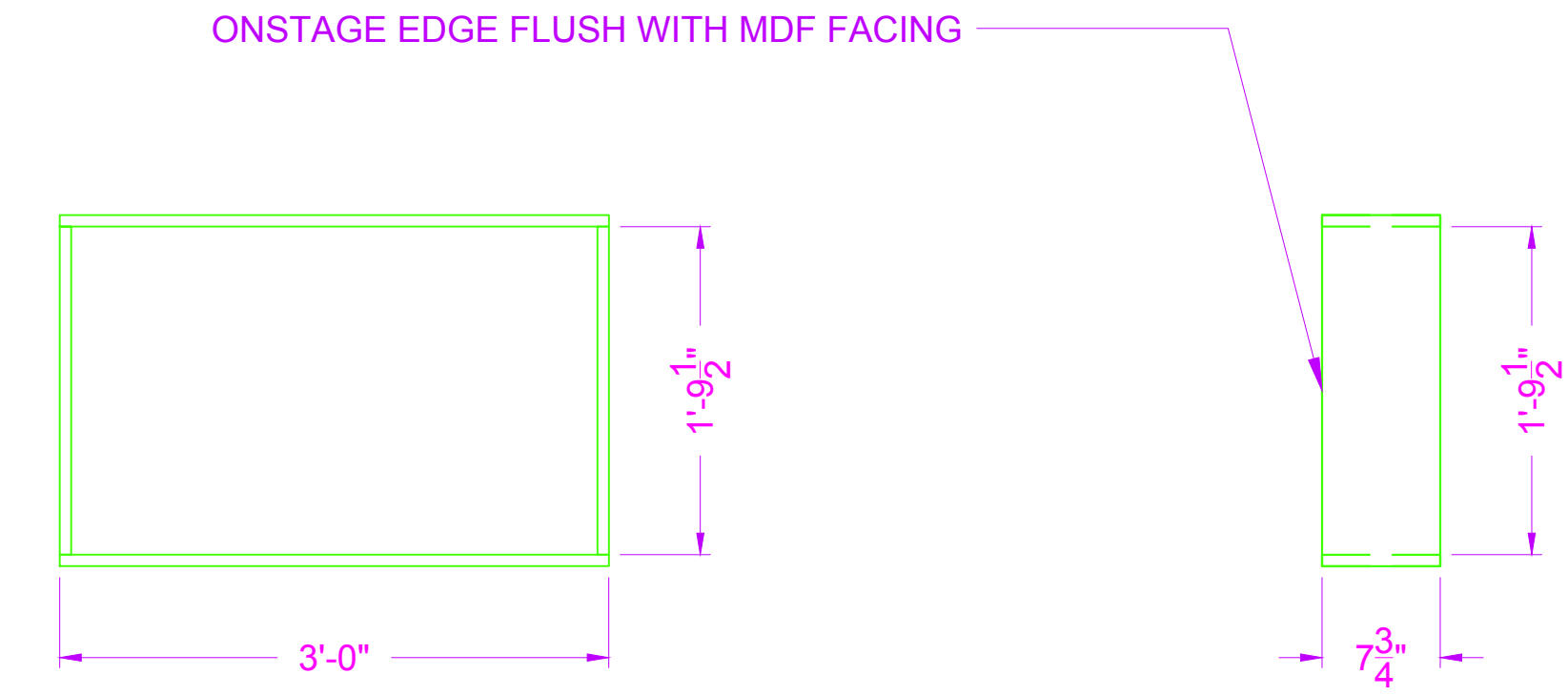

2 DOOR WALL - WINDOW CASING - FRONT VIEW
 SCALE: 1"=1'-0" QTY: (2)

3 DOOR WALL - WINDOW CASING - SIDE VIEW
 SCALE: 1"=1'-0" QTY: (2)

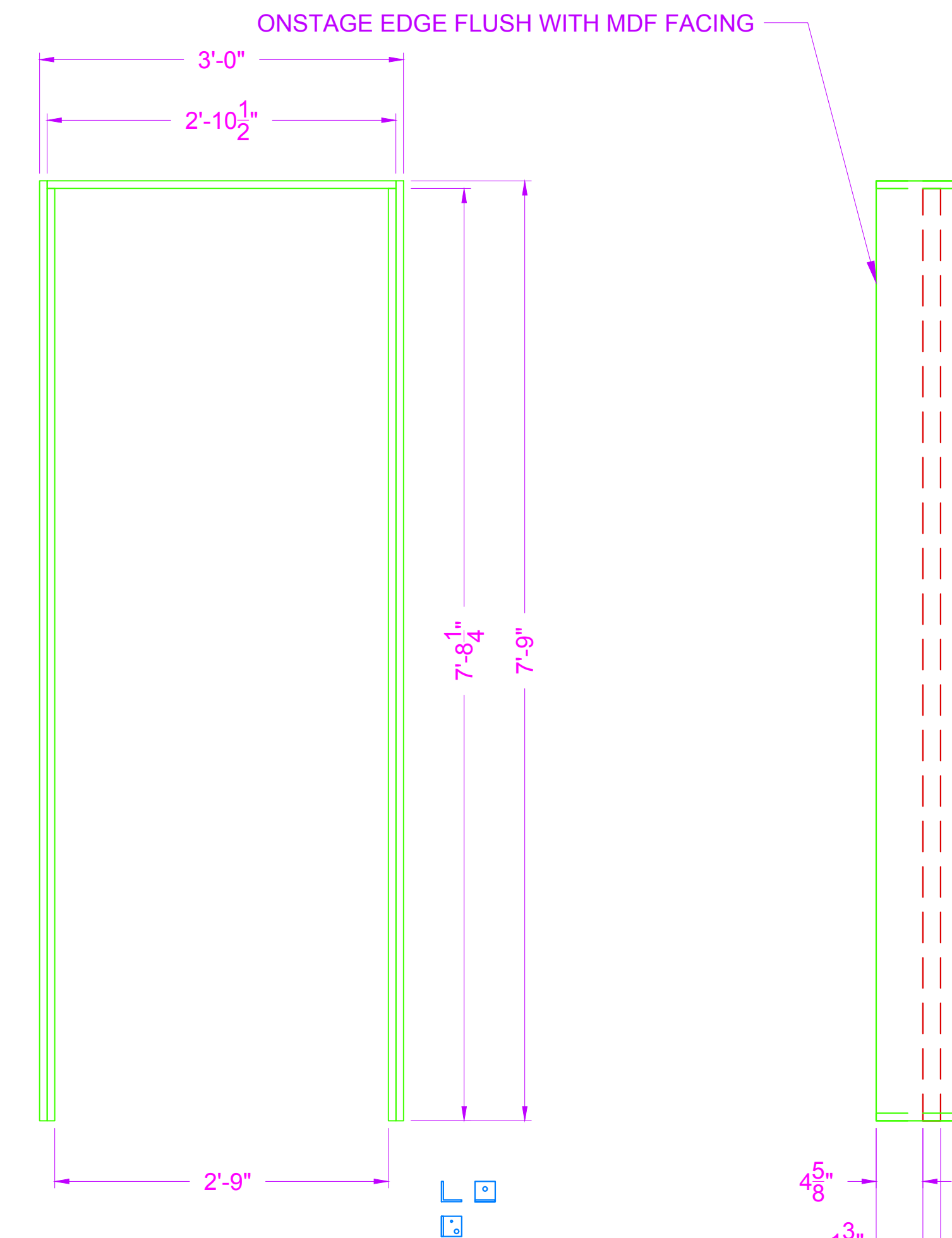

4 DOOR WALL - DOOR JAMB - FRONT VIEW
 SCALE: 1"=1'-0" QTY: (2)

5 DOOR WALL - DOOR JAMB - SIDE VIEW
 SCALE: 1"=1'-0" QTY: (2)



Yale Repertory Theatre
 Yale School Of Drama
 222 York Street
 New Haven, CT 06510

ACCIDENTAL DEATH OF AN ANARCHIST

SR DOOR WALL AND SL DOOR WALL - FRAMING, FACING, AND DOOR

Director:
C. BAYES

Designer:
K. NOLL

T.D.:
J. YOUNG

Scale:
As Noted

Date:
12/6/15

Inventory Code:
450

Plate number:
450-009

Drawn By:
K. MATSUMOTO

File: G:\Productions\2013-2014 Season\VRT3 - Accidental Death of an Anarchist\Technical\Drafting\450 Poice Station Walls\450 Poice Station Walls.dwg

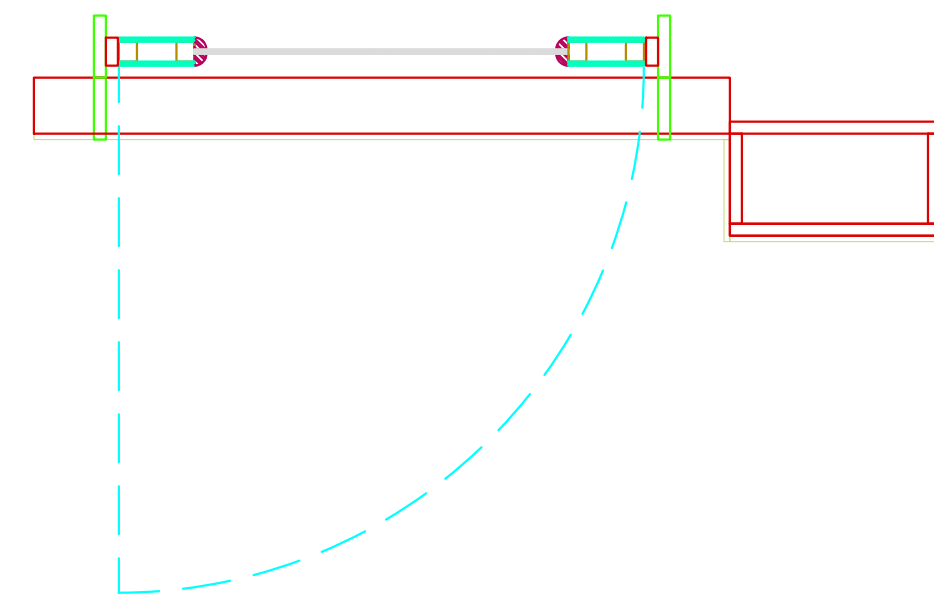

1 SR DOOR WALL - TOP ASSEMBLED VIEW
SCALE: 1"=1'-0"

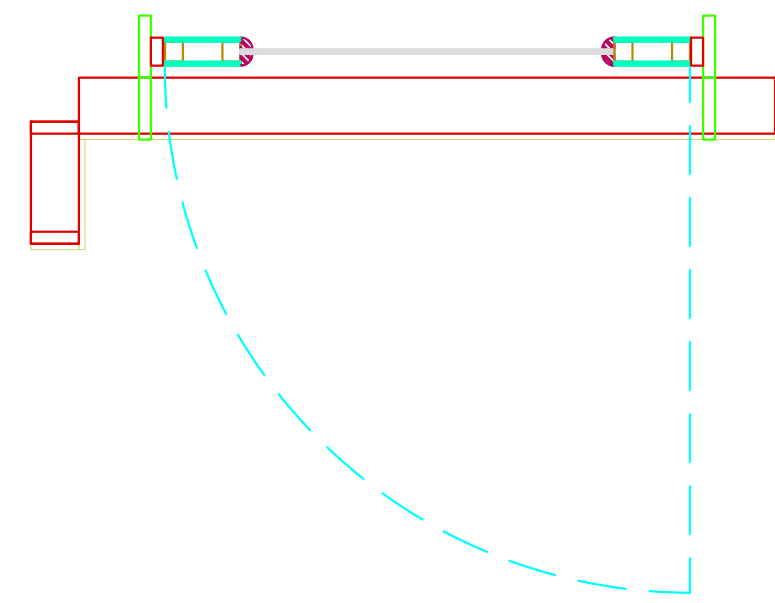

2 SL DOOR WALL - TOP ASSEMBLED VIEW
SCALE: 1"=1'-0"

NOTE:
 DOOR FRAMED WITH $\frac{5}{4} \times 1\frac{1}{4}$ " TRUE POPLAR
 DOOR FACED WITH $\frac{1}{4}$ " MDF
 ACRYLIC SET CENTER IN OPENING
 ACRYLIC CAPTURED BY $\frac{3}{4}$ " HALF ROUND MOULDING
 ON THE OFFSTAGE SIDE OF DOOR, THE MOULDING SHOULD ONLY BE PINNED SO IT CAN BE REMOVABLE
 TRANSOM FRAMED WITH $\frac{5}{4} \times 1\frac{1}{4}$ " TRUE POPLAR
 TRANSOM FACED WITH $\frac{1}{4}$ " MDF
 ACRYLIC SET CENTER IN OPENING
 ACRYLIC CAPTURED BY $\frac{3}{4}$ " HALF ROUND MOULDING
 ON THE OFFSTAGE SIDE OF DOOR, THE MOULDING SHOULD ONLY BE PINNED SO IT CAN BE REMOVABLE

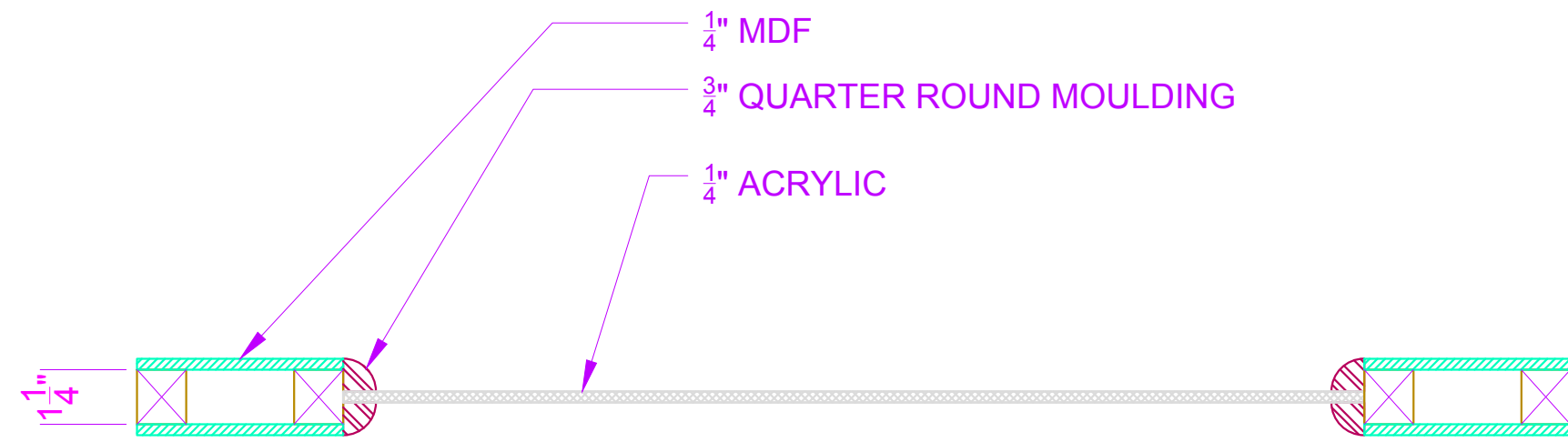

3 DOOR WALL - DOOR - SECTION VIEW
SCALE: 3"=1'-0" QTY: (2)

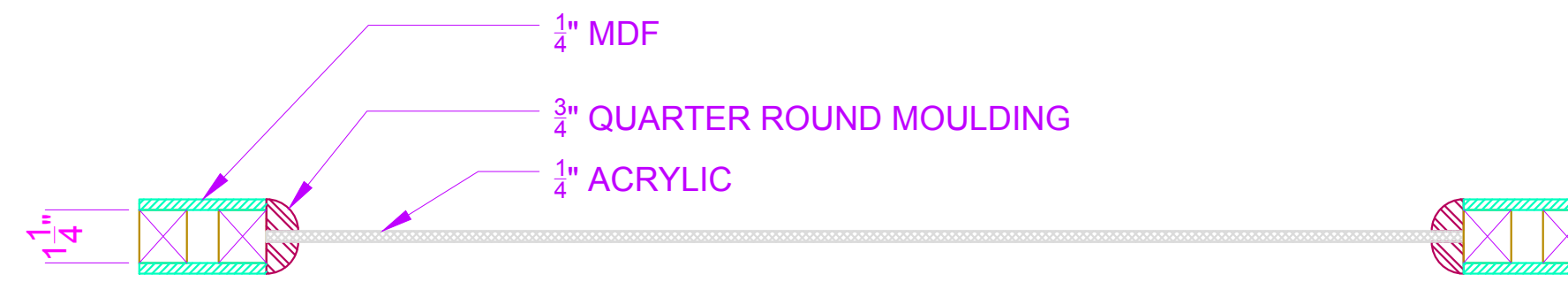

6 DOOR WALL - TRANSOM - SECTION VIEW
SCALE: 3"=1'-0" QTY: (2)

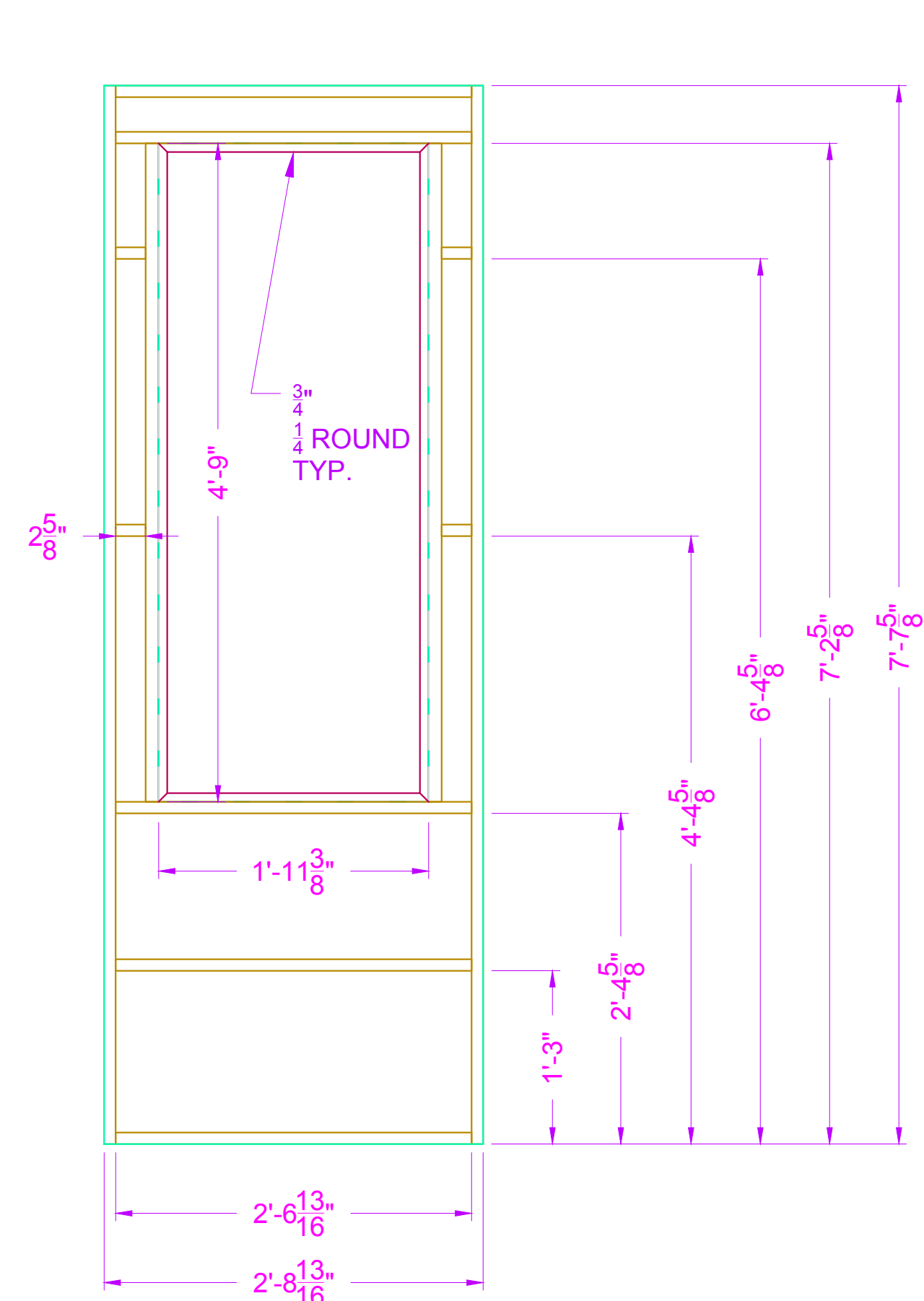

4 DOOR WALL - DOOR - FRONT VIEW
SCALE: 1"=1'-0" QTY: TOTAL (2) REVERSE AND REPEAT

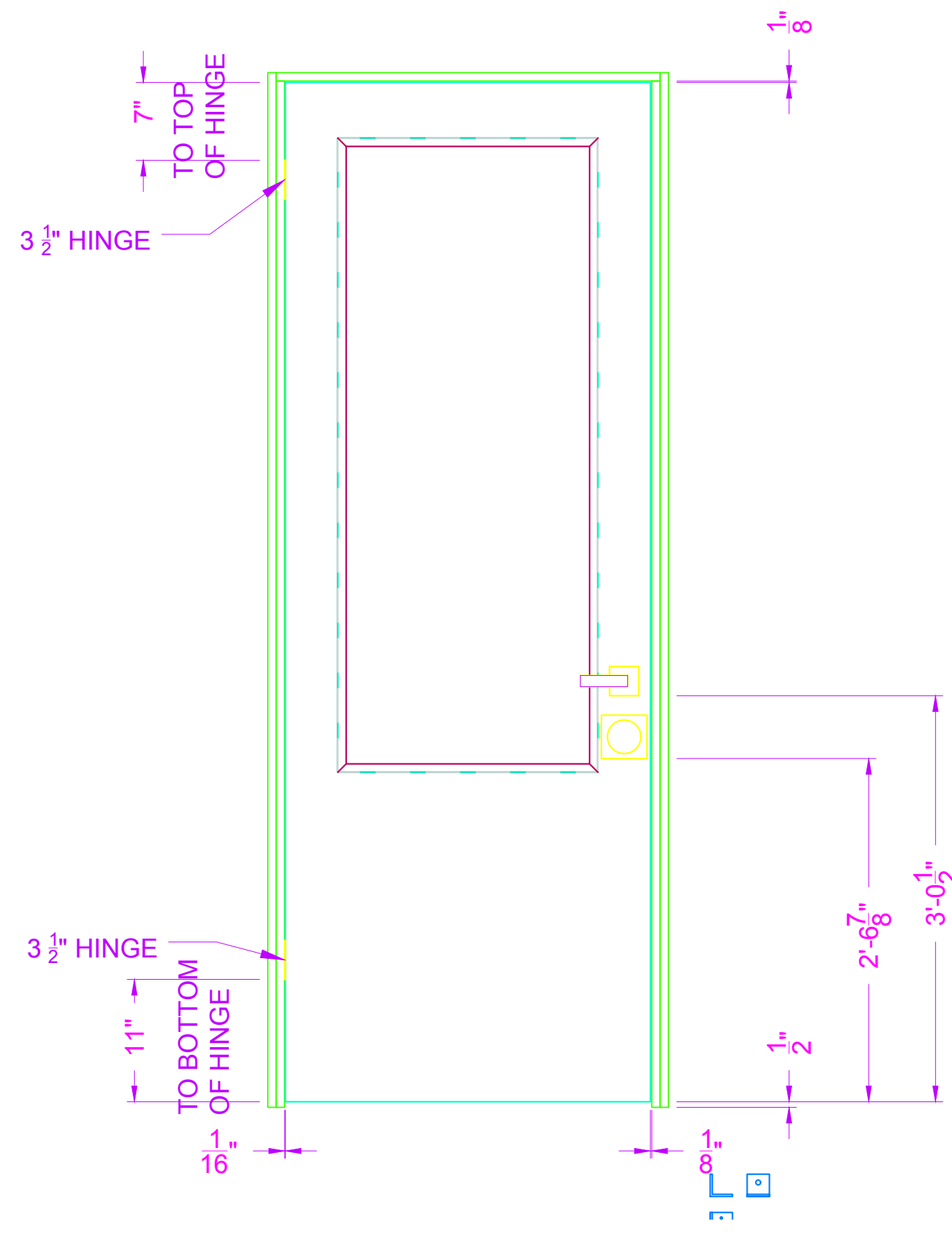

5 DOOR WALL - DOOR HANGING DIMS - FRONT VIEW
SCALE: 1"=1'-0" QTY: TOTAL (2) REVERSE AND REPEAT

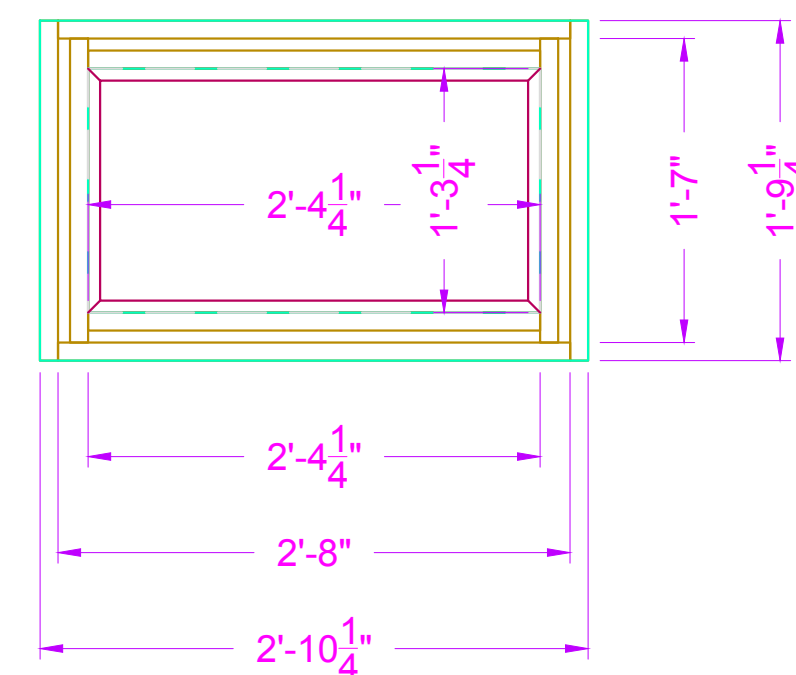

7 DOOR WALL - TRANSOM - FRONT VIEW
SCALE: 1"=1'-0" QTY: TOTAL (2)

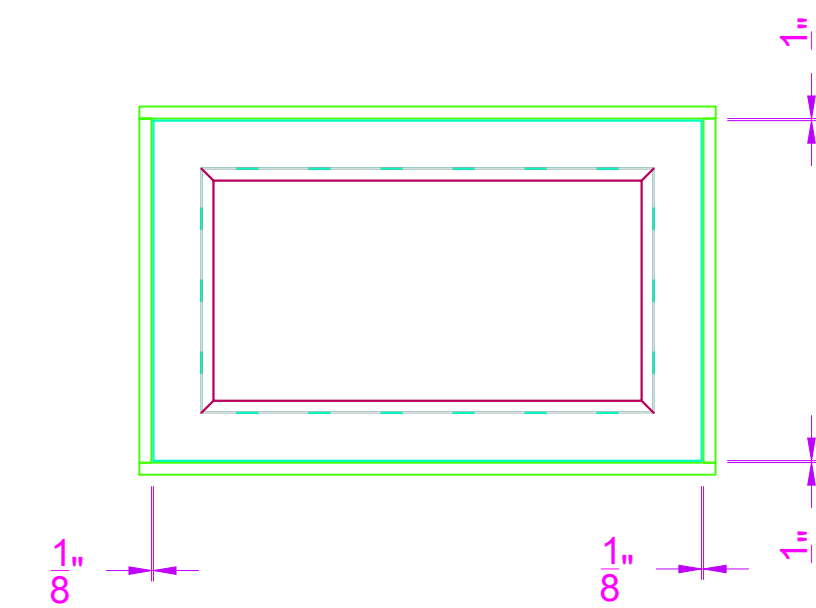

8 DOOR WALL - TRANSOM HANGING DIMS - FRONT VIEW
SCALE: 1"=1'-0" QTY: TOTAL (2)



Yale Repertory Theatre
 Yale School Of Drama
 222 York Street
 New Haven, CT 06510

ACCIDENTAL DEATH OF AN ANARCHIST

SR DOOR WALL AND SL DOOR WALL - CASING

Director:	C. BAYES
Designer:	K. NOLL
T.D.:	J. YOUNG
Scale:	As Noted
Date:	12/6/15
Inventory Code:	450
Plate number:	450-010
Drawn By:	K. MATSUMOTO

Station Walls.dwg
 Accidental Death of an Anarchist\Scenery\Technical\Drafting\450 Poice Station Walls\450 Police Station Walls.dwg

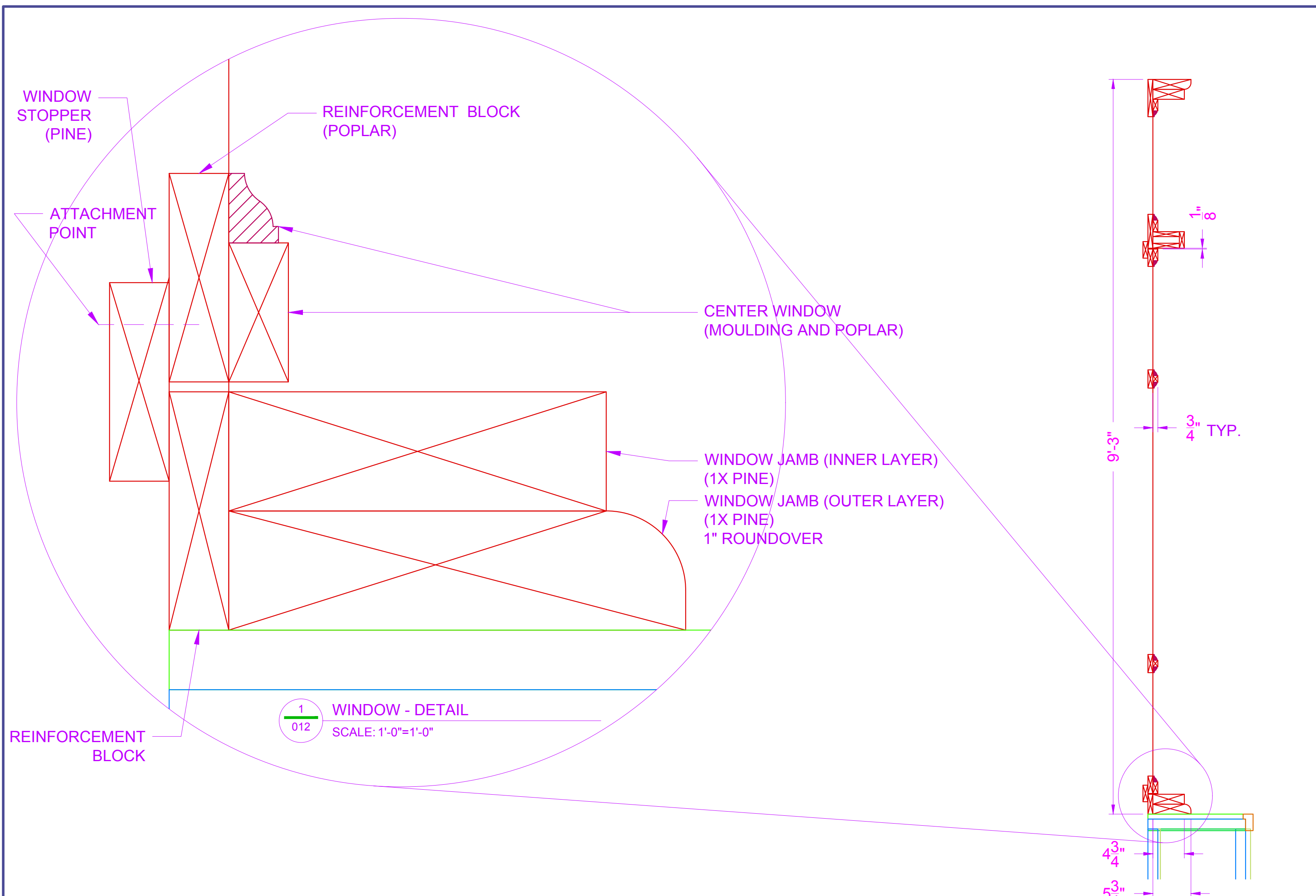

1 WINDOW - DETAIL
SCALE: 1"=1'-0"

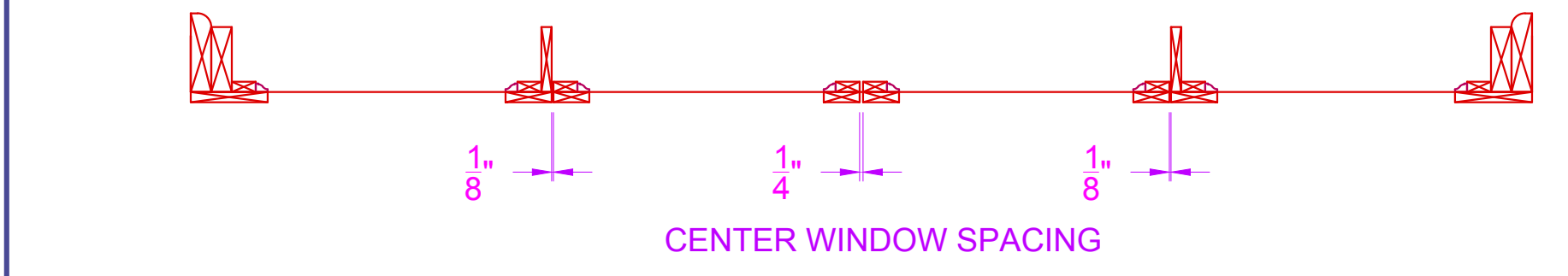

2 WINDOW - SECTION VIEW
SCALE: 1"=1'-0"

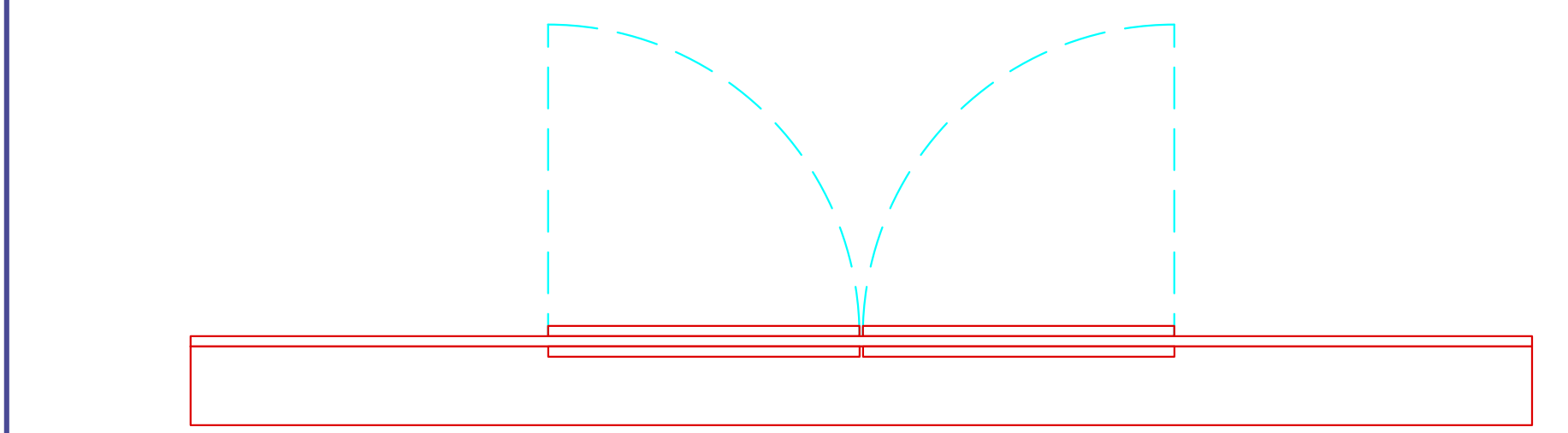

3 WINDOW - TOP VIEW
SCALE: 1"=1'-0"

NOTE:
 JAMB WILL BE BUILT UP LAMINATED 1X CUT DOWN TO SIZE
 WINDOW FRAMING BUILT OUT OF POPLAR CUT TO LISTED SIZE (NOT NECESSARY TO PLANE)
 MOULDING ON THE WINDOWS
 CENTER WINDOWS ARE FUNCTIONAL AND SWING UPSTAGE
 ALL FRAMING WILL BE REINFORCED WITH A POPLAR BLOCK ON THE BACK (SEE SECTION FOR DETAIL)
 FUNCTIONAL CENTER WINDOWS WILL HAVE AN ADDITIONAL BLOCK TO ACT AS A WINDOW STOPPER
 THAT RUNS ALONG THE TOP AND THE BOTTOM (SEE SECTION FOR DETAIL)
 WINDOW JAMB (OUTER LAYER) HAS A 1" ROUND OVER (OR LARGEST SIZE ROUND OVER AVAILABLE)

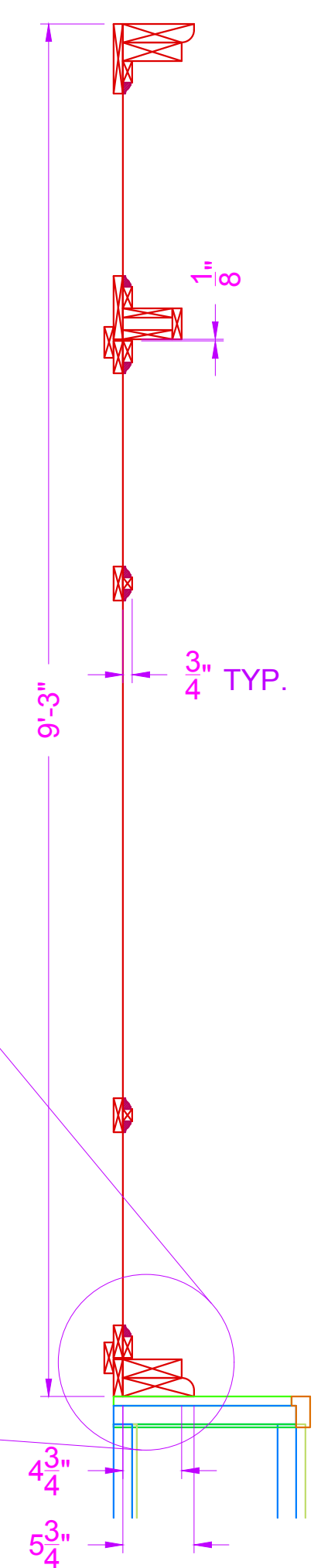

4 WINDOW - SECTION VIEW
SCALE: 1"=1'-0"

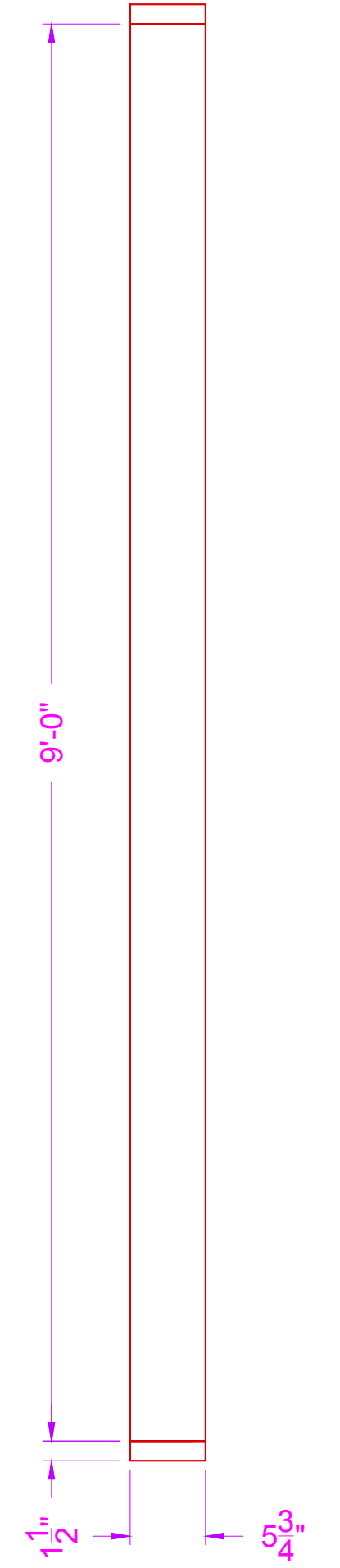

5 WINDOW JAMB (OUTER LAYER) - SIDE VIEW
SCALE: 1"=1'-0"

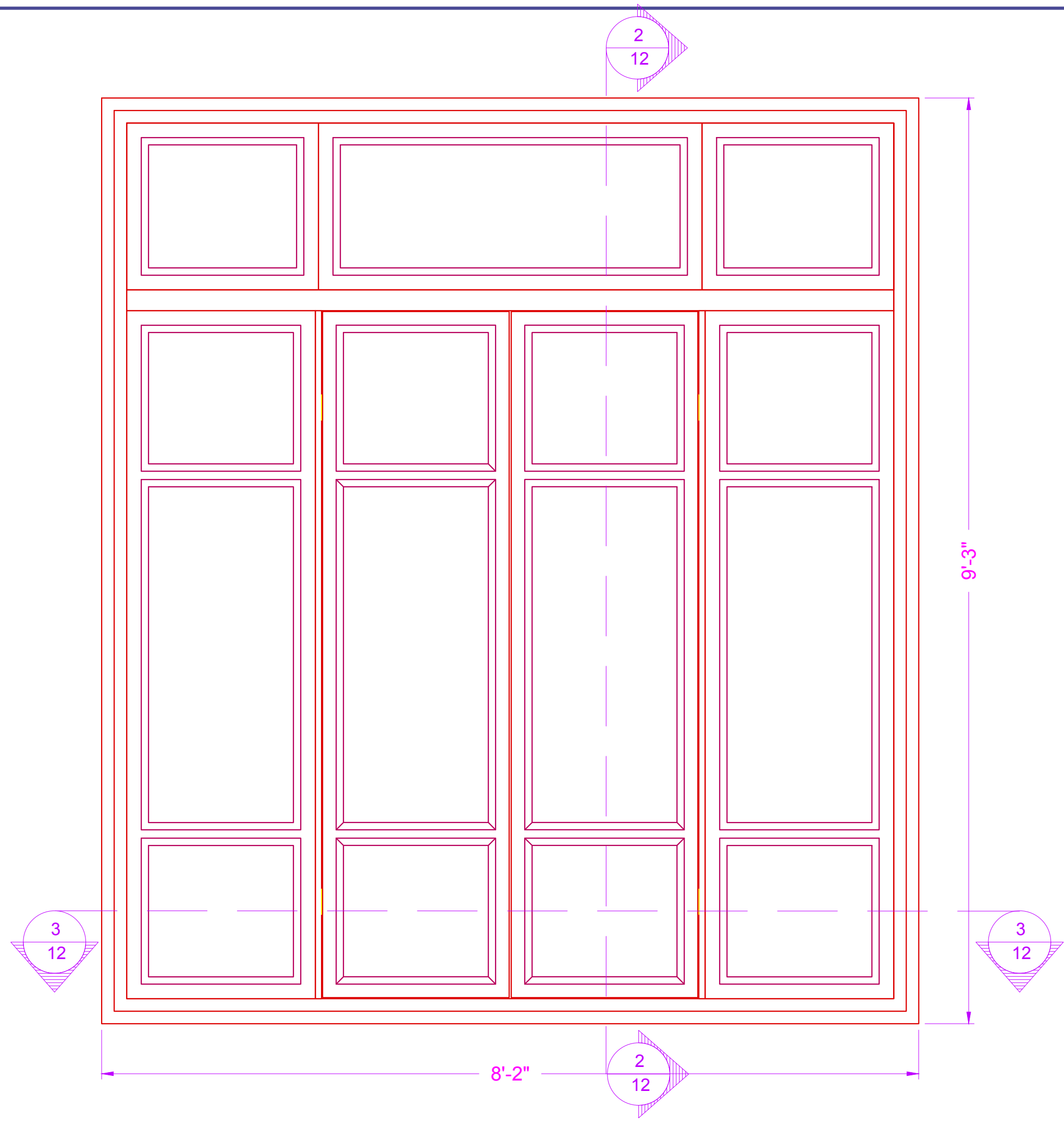

6 WINDOW - ASSEMBLED
SCALE: 1"=1'-0"

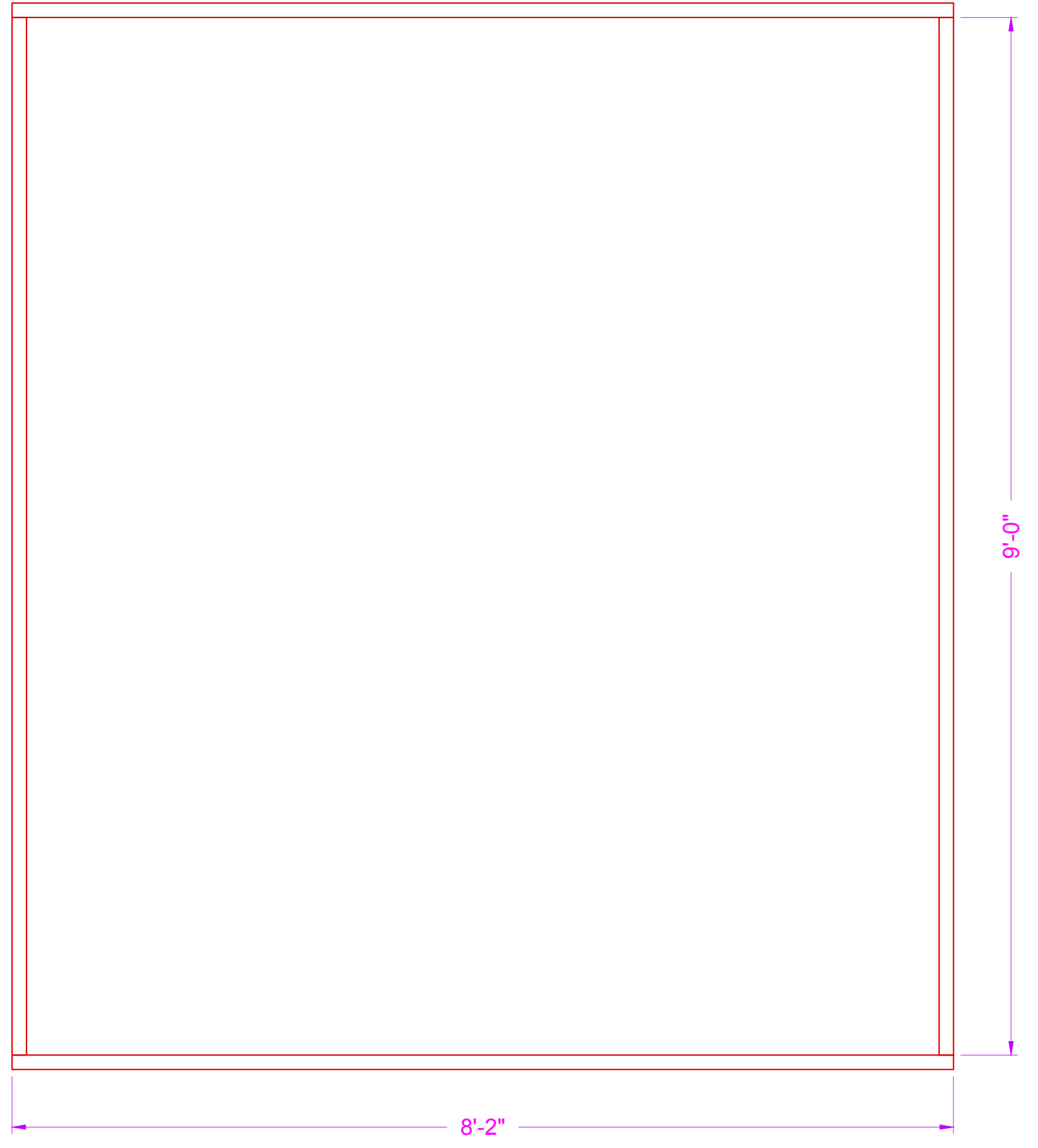

7 WINDOW JAMB (OUTER LAYER) - FRAMING
SCALE: 1"=1'-0"



Yale Repertory Theatre
 Yale School of Drama
 222 York Street
 New Haven, CT 06510

ACCIDENTAL DEATH OF AN ANARCHIST

WINDOW

Director:	C. BAYES
Designer:	K. NOLL
T.D.:	J. YOUNG
Scale:	As Noted
Date:	12/6/15
Inventory Code:	450
Plate number:	450-012

Drawn By:
K. MATSUMOTO

File: G:\Productions\2013-2014 Season\YRT3 - Accidental Death of an Anarchist\Scenery\Technical\Drafting\450 Poice Station Walls\450 Poice Station Walls.dwg

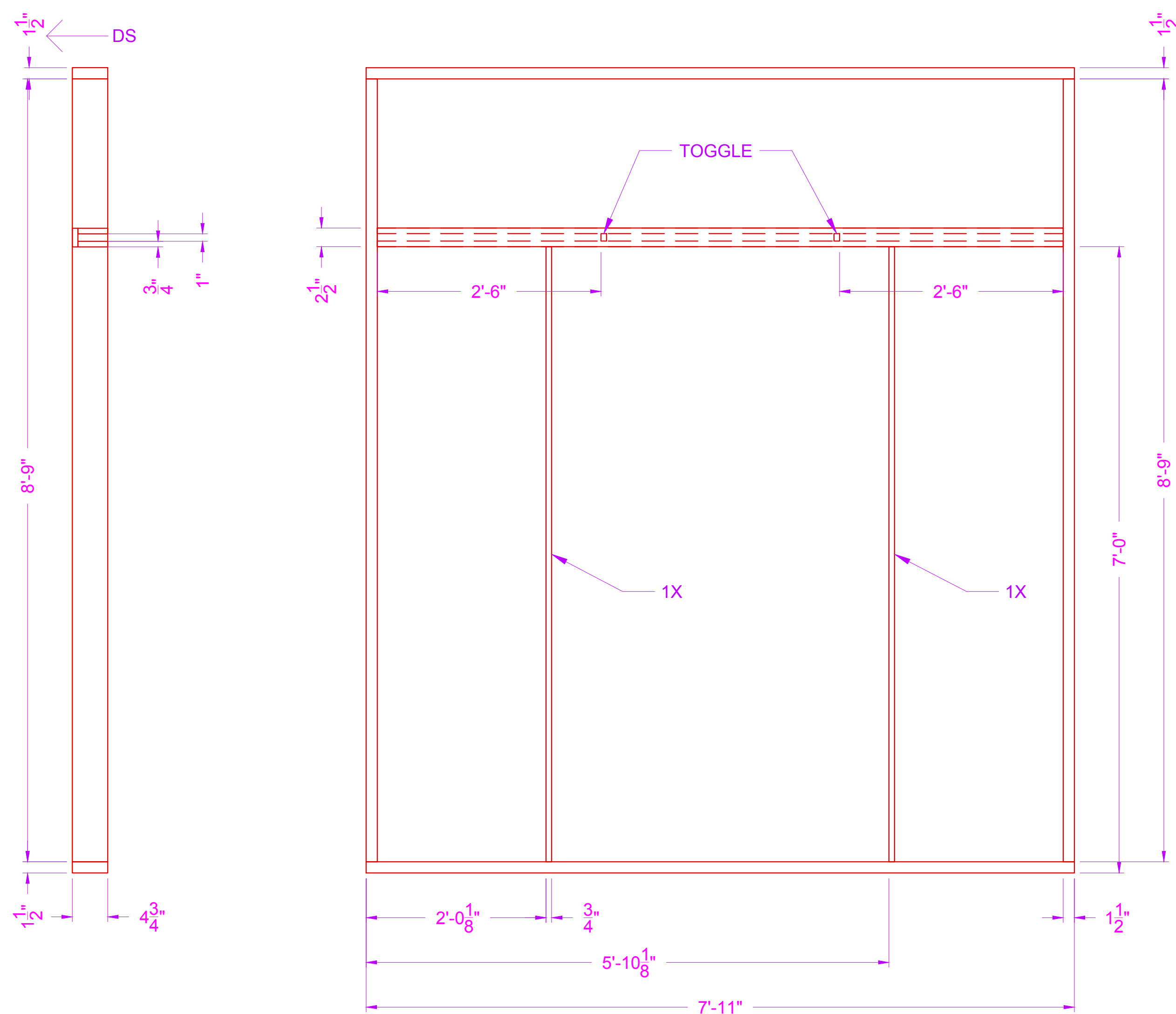

1 WINDOW JAMB (INNER LAYER) - SIDE VIEW
SCALE: 1/2"=1'-0" QTY: (1)

2 WINDOW JAMB (INNER LAYER) - FRAMING
SCALE: 1/2"=1'-0" QTY: (1)

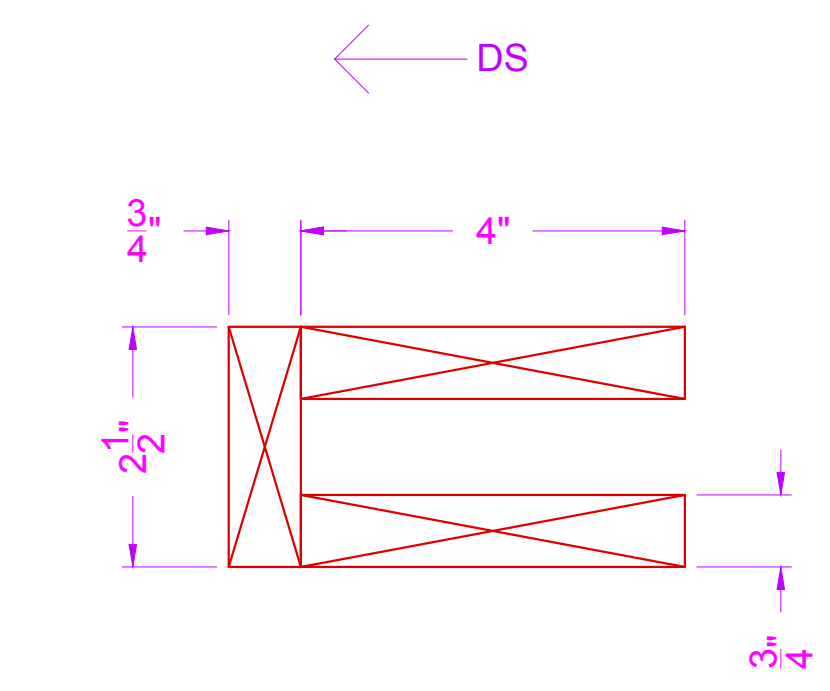

3 WINDOW JAMB (INNER LAYER) MID TOGGLE - DETAIL
SCALE: 6"=1'-0"

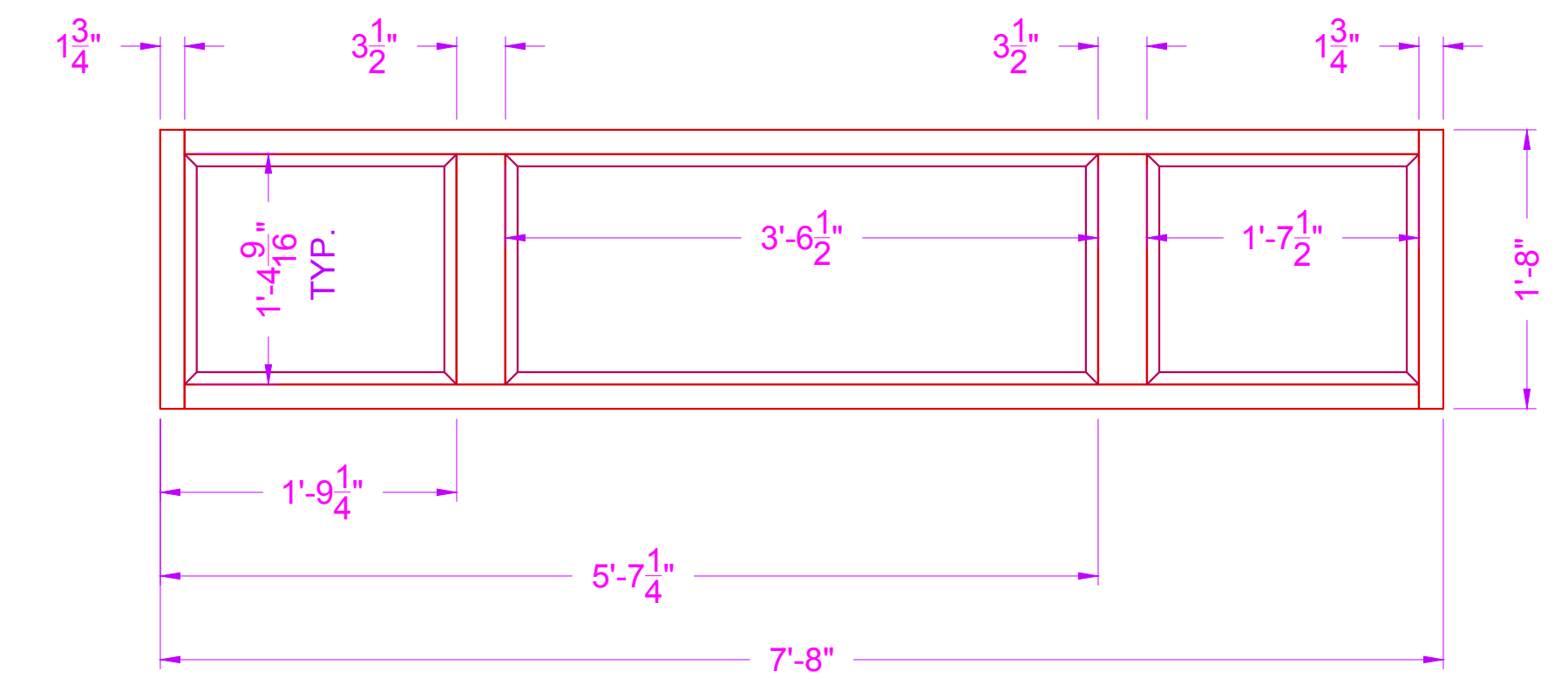

4 UPPER WINDOW
SCALE: 1/2"=1'-0" QTY: (1)

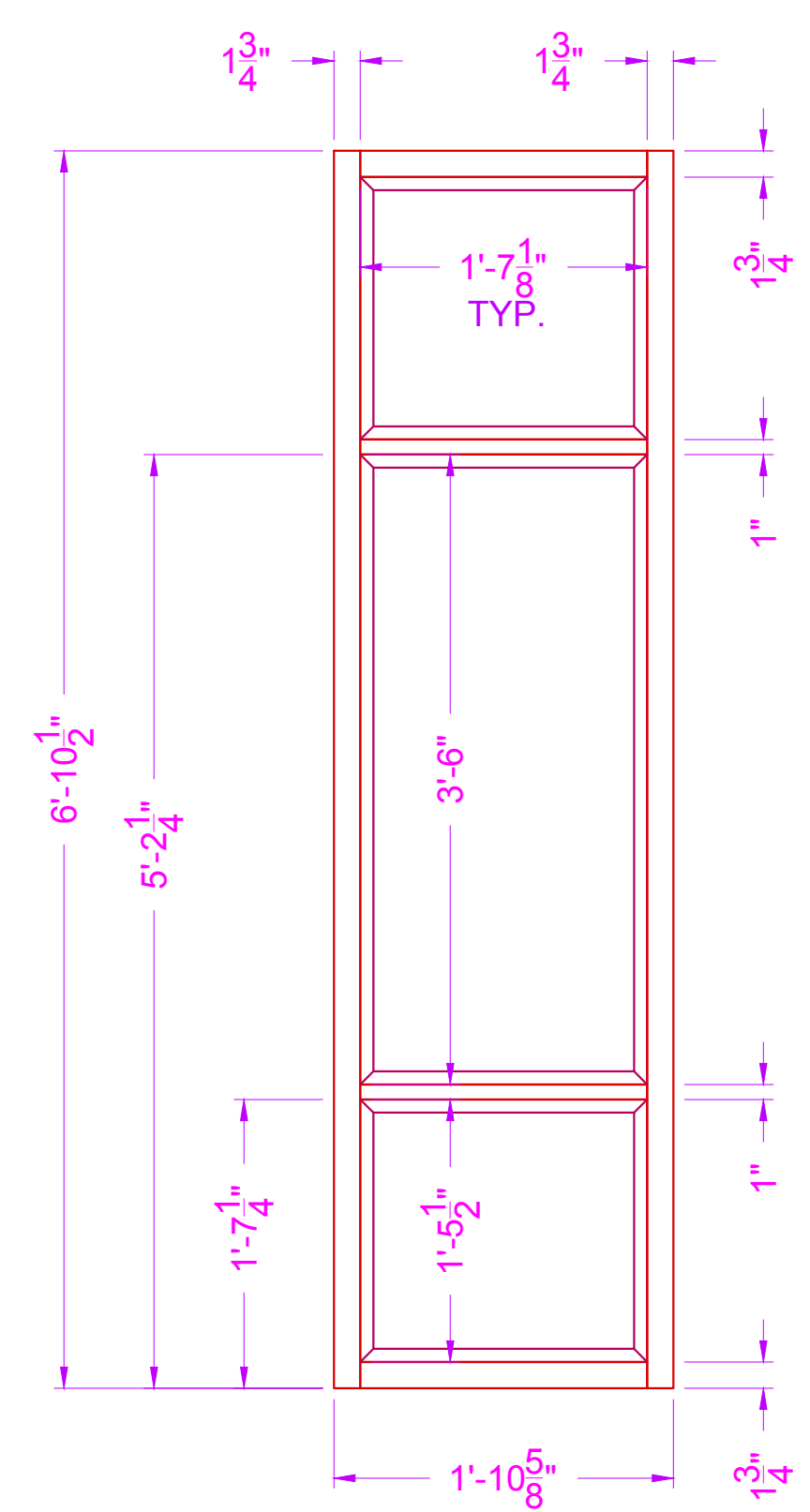

5 BOTTOM OUTER WINDOWS
SCALE: 1/2"=1'-0" QTY: (2)

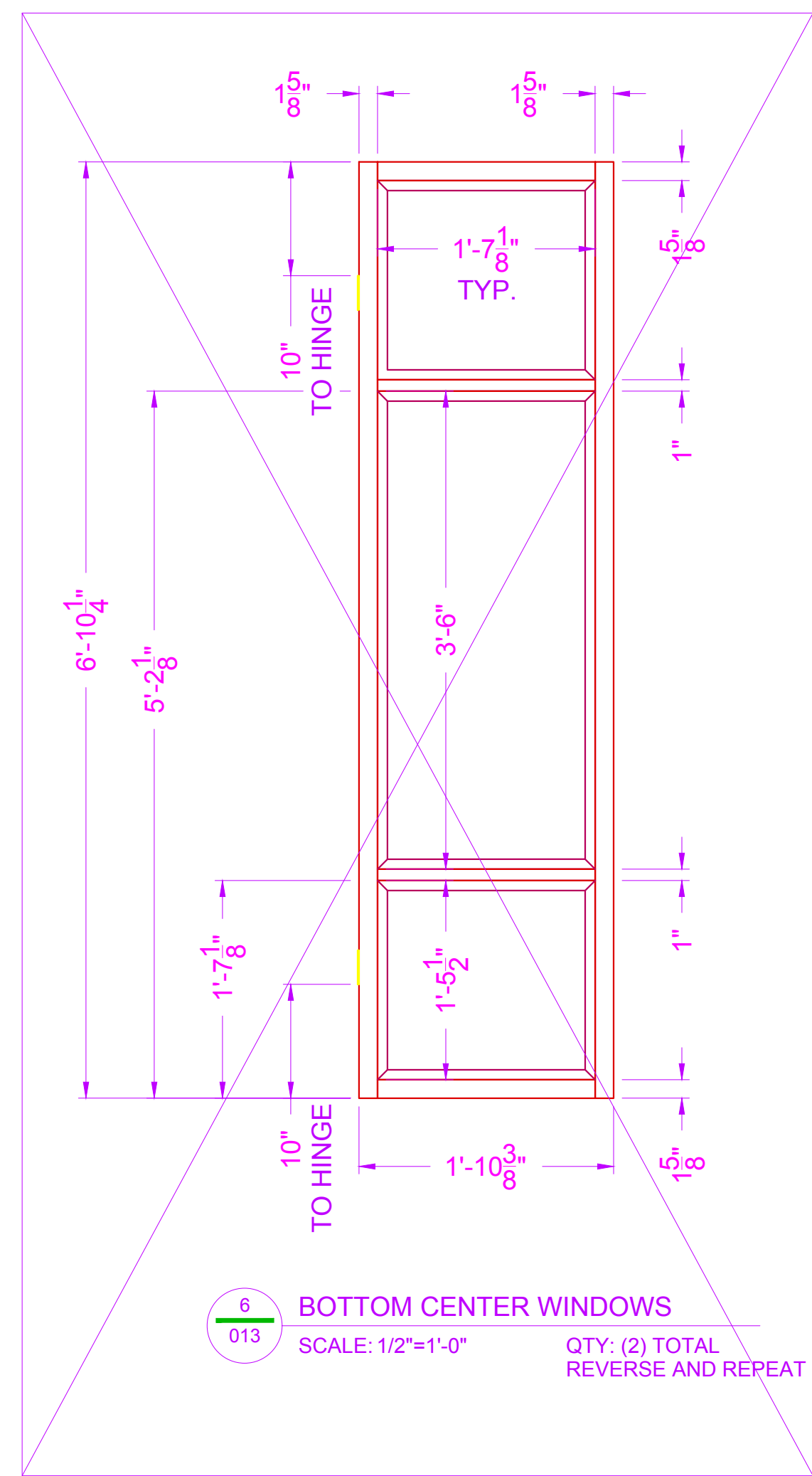

6 BOTTOM CENTER WINDOWS
SCALE: 1/2"=1'-0" QTY: (2) TOTAL REVERSE AND REPEAT

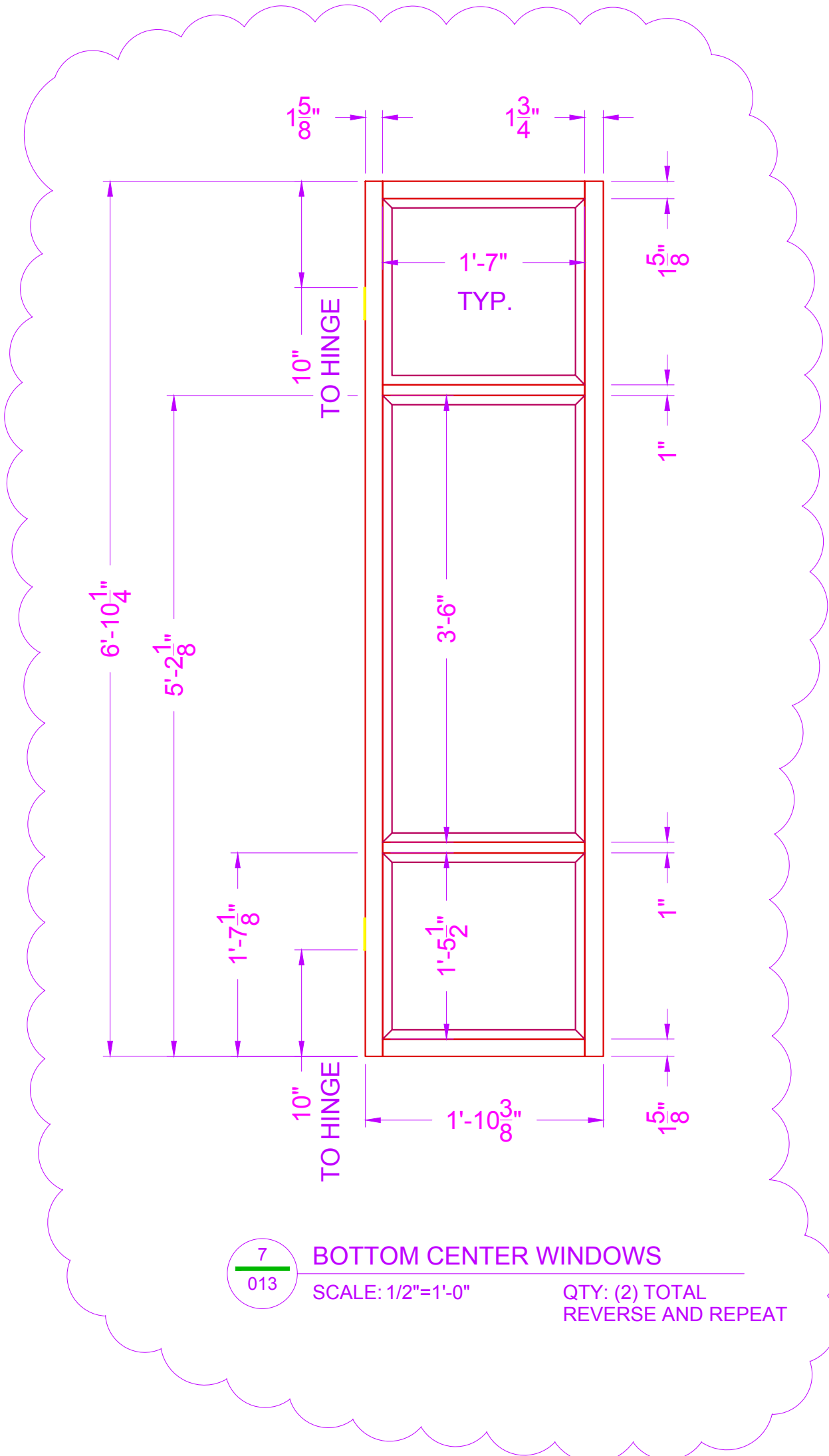

7 BOTTOM CENTER WINDOWS
SCALE: 1/2"=1'-0" QTY: (2) TOTAL REVERSE AND REPEAT

NOTE:
JAMB WILL BE BUILT UP LAMINATED 1X CUT DOWN TO SIZE
WINDOW FRAMING BUILT OUT OF POPLAR CUT TO LISTED SIZE, NOT NECESSARY TO PLANE
MOULDING ON THE WINDOWS
CENTER WINDOWS ARE FUNCTIONAL AND SWING UPSTAGE
USE 3" NARROW BUTT T.P. H517 HINGES (IN INVENTORY)
THE WINDOWS TO BE ASSEMBLED WITH HALF FLAP JOINTS



Yale Repertory Theatre
Yale School Of Drama
222 York Street
New Haven, CT 06510

ACCIDENTAL DEATH OF AN ANARCHIST

WINDOW

Director:
C. BAYES

Designer:
K. NOLL

T.D.:
J. YOUNG

Scale:
As Noted

Date:
12/6/15

Inventory Code:
450

Plate number:
450-013

Drawn By:
K. MATSUMOTO

File: G:\Productions\2013-2014 Season\VRT3 - Accidental Death of an Anarchist\Scenery\Technical\Drafting\450 Poice Station Walls\450 Police Station Walls.dwg